

INSTRUCTION MANUAL

MULTI-INPUT ELECTRONIC LOADING UNITS

LW SERIES

LW75-151Q LW151-151D
LW75-151D LW301-151S

EXTERNAL INTERFACE UNITS
IF-50GP IF-50USB

SAFETY

- Symbol in This Manual

 This symbol indicates where applicable cautionary or other information is to be found.

- Power Source

This equipment operates from a power source that does not apply more than 250V rms between the supply conductors or between both supply conductor and ground. A protective ground connection by way of the grounding conductor in the power cord is essential for safe operation.

- Grounding the Product

This equipment is grounded through the grounding conductor of the power cord. To avoid electrical shock, plug the power cord into a properly wired receptacle before connecting to the equipment input or output terminals.

- Use the Proper Power Cord

Use only the power cord and connector specified for your product.

- Use the Proper Fuse

To avoid fire hazard, use a fuse of the correct type.

- Do not Operate in Explosive Atmospheres

To avoid explosion, do not operate this product in an explosive atmosphere.

- Do not Remove Cover or Panel

To avoid personal injury, do not remove the cover or panel. Refer servicing to qualified personnel.

- If the equipment is used in a manner not specified, the protection provided by the equipment may be impaired.

TABLE OF CONTENTS

SAFETY

1. ABOUT THIS PRODUCT	1
1-1 About This Manual.....	1
1-2 Product Overview	1
1-3 Features.....	1
1-3-1 LW electronic loading unit.....	1
1-3-2 IF-50GP (Option)	2
1-3-3 IF-50USB (Option).....	2
2. SPECIFICATIONS	3
2-1 Maximum Input Rating	3
2-2 Constant-Current Mode.....	3
2-3 Constant-Resistance Mode	4
2-4 Constant-Voltage Mode	4
2-5 Constant-Power Mode.....	5
2-6 Current Limitation	5
2-7 Switching Mode	6
2-8 DC Current Measurement	6
2-9 DC Voltage Measurement	6
2-10 DC Power Measurement	6
2-11 Voltage Remote Sensing	7
2-12 External Contact Control	7
2-13 External Voltage Control.....	7
2-14 Protection Functions.....	7
2-15 Use Conditions, Size, etc.	8
2-16 External Interface Control.....	8
2-17 Communication Specifications of IF-50GP	8
2-18 Communication Specifications of IF-50USB	8
3. PRECAUTIONS	9
3-1 Checking Source Voltage	9
3-2 Connecting Power Cable.....	9
3-3 Instruction on Connecting Input Terminals.....	9
3-4 Installation Environment	10
3-5 Current Limit Setting.....	10
4. PANELS	11
4-1 Front Panel	11
4-2 Rear Panel.....	15
4-3 Optional Board Mount	17
5. BEFORE USING UNIT	18
5-1 Position of Voltage Remote Sensing Selector Switches.....	18
5-2 Connection of Power Supply	19
5-2-1 Connecting with input terminals on front panel	19
5-2-2 Connecting with input terminals on rear panel.....	20
5-3 Turning On Power.....	21
5-3-1 Display when turning on power	21
5-3-2 Setting when turning on power and storing setting	22
5-4 Alarm.....	23
5-4-1 EAR (External alarm).....	23
5-4-2 OHA (Overheat alarm).....	23
5-4-3 OVA (Over-voltage application alarm)	23
5-4-4 OCA (Over-current input alarm)	23
5-5 Limit Functions	24
5-5-1 Over-power limit (OPL).....	24
5-5-2 Current limit (CL)	24
5-6 Replacement of Power Fuse	24
6. FUNCTIONS AND OPERATION PROCEDURES	25
6-1 Operation Method Selecting Function.....	25
6-1-1 Selecting operation method.....	25

6-1-2	Switching method selection	26
6-1-3	Time-out time selection.....	26
6-1-4	Rear contact function selection	27
6-2	Function Setting Mode	28
6-2-1	Function setting mode operation	28
6-2-2	Delay time setting	29
6-2-3	Tracking operation setting	30
6-2-4	Discharge mode setting.....	31
6-2-5	Switching time setting method 1.....	32
6-2-6	Switching time setting method 2.....	33
6-2-7	Changing input voltage display and input power display	34
6-2-8	Changing input value display and set value display	34
6-2-9	Display of two input current values.	35
6-2-10	Increasing and decreasing set values of CC, CV and CP modes	35
6-2-11	Increasing and decreasing set values of CR mode.....	37
6-2-12	Setting CR mode value by means of voltage and current setting.....	39
6-2-13	Increasing and decreasing current limit set value.....	40
6-3	Memory Functions	41
6-3-1	Storing preset values (discharge mode and set value) in EEPROM	41
6-3-2	Storing key settings in EEPROM.....	41
6-3-3	Recalling preset data with PRESET keys	42
6-3-4	Checking preset data and increasing/decreasing set value when MAIN INPUT key is lit.....	42
6-3-5	Initializing set value	43
6-4	Input Functions	44
6-4-1	Turning on input.....	44
6-4-2	Turning off input.....	44
6-5	Switching Functions	45
6-5-1	Turning on/off switching.....	45
6-6	Delay Functions.....	46
6-6-1	Turning on input using delay function.....	46
6-6-2	Turning off input using delay function.....	46
6-7	Tracking Functions	47
6-7-1	Turning on/off tracking operation.....	47
6-7-2	Increasing or decreasing set value in absolute value tracking mode	48
6-7-3	Checking CR mode set resistance in absolute value tracking mode.....	48
6-7-4	Increasing or decreasing set value in % tracking mode	49
6-7-5	Checking set value in % tracking mode	50
6-7-6	Example of increasing/decreasing set values with tracking mode active	51
6-8	Releasing Alarms.....	51
6-8-1	Occurrence of EAR (external alarm) and releasing it	51
6-8-2	Occurrence of OHA (overheat alarm) and releasing it.....	52
6-8-3	Occurrence of OVA (over-voltage application alarm) and releasing it	52
6-8-4	Occurrence of OCA (over-current input alarm) and releasing it.....	52
6-9	Key Lock Function	53
6-10	Usage of Voltage Remote Sensing Function	53
7.	EXTERNAL CONTACT CONTROL.....	54
7-1	Functions	54
7-2	Specifications of Remote Contact Control Connector.....	54
7-3	Usage	55
7-3-1	External alarm terminals	55
7-3-2	Selecting PRESET 1 to 4 keys using external contacts.....	55
7-3-3	Turning ON/OFF input select using external contacts	55
7-3-4	Turning ON/OFF main input using external contacts	56
8.	EXTERNAL VOLTAGE CONTROL	57
8-1	Pins for External Voltage Control	57
8-1-1	Specifications of J2.....	57
8-1-2	Connecting external voltage source and J2	57
8-1-3	Specifications of controls	58
8-2	Usage of External Voltage Control Function	58
8-2-1	Checking set value of external voltage control.....	58

8-2-2 Adjusting set value using external voltage	59
8-2-3 Operation in CC mode.....	60
8-2-4 Relationship between external voltage and set value in CC mode.....	61
8-2-5 Operation in CR/CV/CP mode.....	62
8-2-6 Relationship between external voltage and set value in CR/CV/CP mode	62
9. REMOTE CONTROL	63
9-1 Connection of IF-50GP or /USB	63
9-1-1 Control through GP-IB	63
9-1-2 Control through USB	63
9-1-3 Connection Figure of IF-50GP/USB.....	64
9-1-4 Connection of IF-50GP//USB local bus	65
9-2 Address Setting	65
9-2-1 Addresses.....	65
9-2-2 Address setting	66
9-2-3 Address setting range and set value	66
9-3 Precautions for Using GP-IB or USB	66
9-3-1 Using GP-IB.....	66
9-3-2 Using USB	66
9-4 Precautions for Sending Commands	67
9-4-1 Sending commands.....	67
9-4-2 Command format.....	67
10. COMMANDS	68
10-1 Setting Commands.....	68
10-1-1 Setting units to be controlled	68
10-1-2 PRESET key selection	68
10-1-3 Discharge mode setting.....	68
10-1-4 Main input ON/OFF	69
10-1-5 Input select ON/OFF.....	69
10-1-6 Setting discharge mode set value	70
10-1-7 Setting STEP value of CR mode.....	70
10-1-8 Setting current limit value	71
10-1-9 Saving preset data in EEPROM.....	71
10-1-10 Turning on or off switching select function	71
10-1-11 Setting switching frequency.....	72
10-1-12 Setting switching duty.....	72
10-1-13 Setting switching time.....	72
10-1-14 Changing switching method	73
10-1-15 Turning on/off delay operation.....	73
10-1-16 Setting delay time	73
10-1-17 Saving set values in EEPROM.....	73
10-1-18 Saving discharge mode set value in EEPROM.....	74
10-1-19 Saving current limit value in EEPROM.....	74
10-1-20 Setting time-out time.....	74
10-1-21 Resetting alarms.....	74
10-1-22 Selecting input value display channel	75
10-1-23 Selecting input value to be displayed.....	75
10-1-24 Local setting (Canceling key locking)	75
10-1-25 Setting lockout status	75
10-1-26 Tracking setting	76
10-1-27 Setting tracking mode.....	76
10-1-28 Turning On/Off tracking operation	76
10-1-29 Increasing/decreasing set value in tracking operation	77
10-2 Query Commands	77
10-2-1 Sending system addresses of controlled units.....	77
10-2-2 Sending addresses of all slave units.....	77
10-2-3 Sending option board ID and model ID of unit.....	78
10-2-4 Query about input value	78
10-2-5 Query about selected PRESET key	79
10-2-6 Query about discharge mode	79
10-2-7 Query about main input On/Off status.....	80

10-2-8 Query about input select status.....	80
10-2-9 Inquiry about set values.....	80
10-2-10 Query about STEP value in CR mode	81
10-2-11 Query about set current limit	81
10-2-12 Query about switching select status.....	82
10-2-13 Query about switching frequency.....	82
10-2-14 Query about switching duty	82
10-2-15 Query about set switching time	83
10-2-16 Query about switching method.....	83
10-2-17 Query about delay function On/Off status	83
10-2-18 Query about set delay time	84
10-2-19 Query about unit ID number.....	84
10-2-20 Query about set time-out time	84
10-2-21 Query about alarm status	85
10-2-22 Query about limit operation status.....	85
10-2-23 Query about input value display channel	86
10-2-24 Query about displayed input value	86
10-2-25 Query about local lockout status	86
10-2-26 Query about tracking setting	87
10-2-27 Query about tracking mode	87
10-2-28 Query about tracking operation On/Off status.....	87
10-2-29 Query about % tracking mode set value	88
10-3 Command List	89
10-3-1 Setting commands.....	89
10-3-2 Query commands	90
11. TROUBLE-LOOKING PHENOMENA	91
12. OUTSIDE DIMENSIONS	92

1. ABOUT THIS PRODUCT

1-1 About This Manual

Applicable models: LW series electronic loading units

LW75-151Q, LW75-151D, LW151-151D and LW301-151S

Optional interface units for the LW series electronic loading units

IF-50GP: Interface for GP-IB communication

IF-50USB: Interface for USB communication

1-2 Product Overview

The LW series is a multi-input type electronic loading unit with several isolated input terminals. The basic function of the LW series is the CC discharge mode using the input terminals on the rear panel. Three discharge modes (CR, CV and CP), front input terminals, voltage remote sensing functions, and control functions according to external analog voltages are also available as optional functions on request. In addition, the LW series provides tracking, delay and four-point preset functions for a wide variety of applications.

1-3 Features

1-3-1 LW electronic loading unit

- Tracking function (exclusive of LW301-151S)

The LW series employs a tracking function, which may vary the voltage and current of each channel at the same ratio (or absolute value) simultaneously. It is possible to use the tracking function independently in each channel or vary all channels simultaneously.

- Delay function (exclusive of LW301-151S)

The LW series has a delay function, which delays turning on or off the input of a specified channel by specified time when turning on several channels. It is possible to set the delay time of each channel independently in the range from 0.01 to 10.00 seconds.

- Preset function

The LW series has four-point preset memories, each of which may store the discharge mode and set values of a channel. This function enables easy changing of the set values.

- Input value display function

The LW series displays the voltage, current and power on four-digit, seven-segment red LEDs.

- Individual input ON/OFF setting function

It is possible to turn on or off the input of each channel individually. The input ON/OFF condition of each channel is indicated with an LED clearly.

- Individual switching ON/OFF setting function

It is possible to turn on or off the input of each channel individually. The switching ON/OFF condition of each channel is indicated with an LED clearly.

- Switching time setting method selecting function

It is possible to select the switching time setting; "frequency and duty" or "Ta time and Tb time".

- External contact control function

It is possible to select the PRESET 1 to 4 keys, turn on or off the individual input (except the LW301-151S), turn on or off the main input, and input or output alarms through the external contacts.

- Voltage remote sensing function (Factory option)

Each channel has voltage remote sensing terminals. This function enables voltage measurement of the power supply by compensating for the voltage drop of the wires.

- Slide terminal structure (Factory option)

The input terminals on the front panel have a sliding structure. This structure fixes wires to the terminals firmly and securely.

1-3-2 IF-50GP (Option)

- Connect the LW series with a computer through the GP-IB. GP-IB connection allows fourteen LW electronic loading units to be connected with a computer directly.

- It is also possible to connect thirty-one LW units with each LW unit directly connected with the computer using a pair of twisted pair cables and remote-control them. Thus, the IF-50GP unit enables construction of a large-scale system.

NOTE: This option is not available to an LW series with the external analog voltage control functions added by factory option.

1-3-3 IF-50USB (Option)

- Connect the LW series with a computer through USB. USB connection allows thirty-two LW electronic loading units to be connected with a computer directly.

- It is also possible to connect thirty-one LW units with each LW unit directly connected with the computer using a pair of twisted pair cables and remote-control them. Thus, the IF-50USB unit enables construction of a large-scale system.

NOTE: This option is not available to an LW series with the external analog voltage control functions added by factory option.

2. SPECIFICATIONS

2-1 Maximum Input Rating

Item	Model	
Input voltage	LW75-151Q LW75-151D	H current range: 75 W, L current range: 12.5 W
	LW151-151D	H current range: 150 W, L current range: 25 W
	LW301-151S	H current range: 300 W, L current range: 50 W
Input current	LW75-151Q LW75-151D	H current range: 15 A, L current range: 2.5 A
	LW151-151D	H current range: 30 A, L current range: 5 A
	LW301-151S	H current range: 60 A, L current range: 10 A
	LW301-151S front input type	H current range: 30 A, L current range: 10 A
Application voltage	All models	150 V
Input terminals	LW75-151Q	4 (Std.: rear, factory option: front)
	LW75-151D LW151-151D	2 (Std.: rear, factory option: front)
	LW301-151S	1 (Std.: rear, factory option: front)

2-2 Constant-Current Mode

Item	Model	
Input vol. range	All models	Rear: 1 to 150 V front: 1.5 to 150 V
Setting range	LW75-151Q LW75-151D	H current range: 0.000 to 15.750 A (0 to 105% FS) L current range: 0.0000 to 2.6250 A (0 to 105% FS)
	LW151-151D	H current range: 0.000 to 31.500 A (0 to 105% FS) L current range: 0.0000 to 5.3000 A (0 to 105% FS)
	LW301-151S	H current range: 0.000 to 63.000 A (0 to 105% FS) L current range: 0.0000 to 10.500 A (0 to 105% FS)
	LW301-151S front input type	H current range: 0.000 to 31.500 A (0 to 105% FS) L current range: 0.0000 to 10.500 A (0 to 105% FS)
Theoretical resolution	LW75-151Q LW75-151D	H current range: 1 mA L current range: 0.1 mA
	LW151-151D	H current range: 2 mA L current range: 0.2 mA
	LW301-151S	H current range: 5 mA L current range: 1 mA
Setting accuracy	All models	$\pm(0.5\% \text{ SET} + 0.3\% \text{ FS})$ at 23 $\pm 5^\circ\text{C}$ 1% FS current or more
Ripple noise	LW75-151Q LW75-151D	H current range: 5 mA (Actual value measured in 5 to 1MHz range) L current range: 3 mA (Actual value measured in 5 to 1MHz range)
	LW151-151D	H current range: 10 mA (Actual value measured in 5 to 1MHz range) L current range: 6 mA (Actual value measured in 5 to 1MHz range)
	LW301-151S	H current range: 20 mA (Actual value measured in 5 to 1MHz range) L current range: 10 mA (Actual value measured in 5 to 1MHz range)
Temperature coefficient	All models	100ppm/ $^\circ\text{C}$: time of rated current

- The constant-current circuit of the LW series has an internal reference power source for each preset. Thus, when the same current is set for all presets, the control current may differ with the presets.

2-3 Constant-Resistance Mode

Item	Model	
Input vol. range	All models	Rear: 0 to 150 V, front: 0 to 150 V
Setting range Resistances shown on right correspond to STEP values of 3 to 30000.	LW75-151Q LW75-151D	H current range: 1 k to 0.1 Ω L current range: 6 k to 0.6 Ω
	LW151-151D	H current range: 500 to 0.05 Ω L current range: 3 k to 0.3 Ω
	LW301-151S	H current range: 250 to 0.025 Ω L current range: 1.5 k to 0.15 Ω
Theoretical resolution	LW75-151Q LW75-151D	H current range: 333 μ S (= 1/3 k Ω) L current range: 55.5 μ S (= 1/18 k Ω)
	LW151-151D	H current range: 666 μ S (= 1/1.5 k Ω) L current range: 111 μ S (= 1/9 k Ω)
	LW301-151S	H current range: 1.33 mS (= 1/750 Ω) L current range: 222 μ S (= 1/4.5 k Ω)
Setting accuracy	All models	$\pm(2\% V_{in}/R_{set} + 1.5\% \text{ FS current})$ $V_{in} = 1.5$ or more, at $23 \pm 5^{\circ}\text{C}$, set current: 10% FS current or more
Ripple noise	LW75-151Q LW75-151D	H current range: 5 mA (Actual value measured in 5 to 1MHz range) L current range: 3 mA (Actual value measured in 5 to 1MHz range)
	LW151-151D	H current range: 10 mA (Actual value measured in 5 to 1MHz range) L current range: 6 mA (Actual value measured in 5 to 1MHz range)
	LW301-151S	H current range: 20 mA (Actual value measured in 5 to 1MHz range) L current range: 10 mA (Actual value measured in 5 to 1MHz range)
Temperature coefficient	All models	1000ppm/ $^{\circ}\text{C}$: time of rated electric power and time of rated current

- The resistances shown above are calculated using the following expression: Resistance = $1/(\text{theoretical resolution} \times \text{STEP})$
- The constant-resistance circuit of the LW series has an internal reference power source for each preset. Thus, when the same resistance is set for all presets, the control resistance may differ with the presets.
- The constant-resistance circuit of the LW series switches three circuits to execute resistance control according to the set steps. Thus, the set resistance may change greatly in the setting accuracy range when the circuit is switched (at two points between the set steps 300 and 301 and steps 3000 and 3001).

2-4 Constant-Voltage Mode

Item	Model	
Setting range	All models	0.00 to 157.50 V (0 to 105% FS)
Min. operating current	All models	1% FS current
Theoretical resolution	All models	10 mV
Setting accuracy	All models	$\pm(0.5\% \text{ SET} + 0.3\% \text{ FS})$ at $23 \pm 5^{\circ}\text{C}$ Application voltage -- Front: 1.5 V or more, rear: 1 V or more
CV temperature coefficient	All models	150 ppm/ $^{\circ}\text{C}$: time of rated voltage

- The constant-voltage circuit of the LW series has an internal reference power source for each preset. Thus, when the same voltage is set for all presets, the control voltage may differ with the presets.

2-5 Constant-Power Mode

Item	Model	
Input vol. range	All models	H voltage range: 5 to 150 V L voltage range: 1 to 15 V
Setting range	LW75-151Q LW75-151D	H current range: 3.75 to 78.75 W (5 to 105% FS) L current range: 0.625 to 13.12 W (5 to 105% FS)
	LW151-151D	H current range: 7.50 to 157.50 W (5 to 105% FS) L current range: 1.25 to 26.25 W (5 to 105% FS)
	LW301-151S	H current range: 15.00 to 315.00 W (5 to 105% FS) L current range: 2.500 to 52.500 W (5 to 105% FS)
Theoretical resolution	LW75-151Q LW75-151D	H current range: 10 mW L current range: 1 mW
	LW151-151D	H current range: 20 mW L current range: 2 mW
	LW301-151S	H current range: 50 mW L current range: 5 mW
Setting accuracy	All models	$\pm(5\% \text{ SET} + 2\% \text{ FS})$ at $23 \pm 5^\circ\text{C}$, at constant current over 5%
Ripple noise	LW75-151Q LW75-151D	H current range: 8 mA (Actual value measured in 5 to 1MHz range) L current range: 5 mA (Actual value measured in 5 to 1MHz range)
	LW151-151D	H current range: 16 mA (Actual value measured in 5 to 1MHz range) L current range: 10 mA (Actual value measured in 5 to 1MHz range)
	LW301-151S	H current range: 32 mA (Actual value measured in 5 to 1MHz range) L current range: 20 mA (Actual value measured in 5 to 1MHz range)
Temperature coefficient	All models	1000ppm/°C: time of rated electric power and time of rated current

The constant-power circuit of the LW series has an internal reference power source for each preset. Thus, when the same power is set for all presets, the control power may differ with the presets.

2-6 Current Limitation

Item	Model	
Setting range	LW75-151Q LW75-151D	H current range: 0.75 to 15.75 A (5 to 105% FS) L current range: 0.125 to 2.625 A (5 to 105% FS)
	LW151-151D	H current range: 1.50 to 31.50 A (5 to 105% FS) L current range: 0.250 to 5.250 A (5 to 105% FS)
	LW301-151S	H current range: 3.00 to 63.00 A (5 to 105% FS) L current range: 0.50 to 10.50 A (5 to 105% FS)
	LW301-151S front input type	H current range: 3.00 to 31.500 A (10 to 105% FS) L current range: 0.50 to 10.500 A (5 to 105% FS)
Theoretical resolution	LW75-151Q LW75-151D	H current range: 10 mA L current range: 1m A
	LW151-151D	H current range: 20 mA L current range: 2m A
	LW301-151S	H current range: 50 mA L current range: 10m A
Setting accuracy	All models	$\pm(1\% \text{ SET} + 1.5\% \text{ FS})$ at $23 \pm 5^\circ\text{C}$

2-7 Switching Mode

Item	
Operation mode	Preset value 1/2 or 3/4 switching
Setting method 1: Frequency and duty	
Frequency setting range	1 to 500 Hz
Frequency setting accuracy	±5% SET
Frequency setting resolution	1 Hz
Duty setting range	5 to 95%
Duty setting accuracy	3% SET
Duty setting resolution	1%
Setting method 2: Ta time and Tb time	
Time setting range	Ta & Tb time: 0.1 to 900.0 ms
Time setting accuracy	±5% SET
Time setting resolution	0.1 ms

- Setting method 1 and setting method 2 may not be used simultaneously. Select either method when turning on power.
- The time setting range of method 2 is 0.1 to 900.0 ms. However, time exceeding the preset frequency and duty range of method 1 may not be set.
 Frequency setting range = $1/(T_a \text{ time} + T_b \text{ time})$ within 1 to 500 Hz
 Duty setting range = $\{T_a \text{ time}/(T_a \text{ time} + T_b \text{ time})\} \times 100$ within 5% to 95%

2-8 DC Current Measurement

Item	Model	
Resolution	LW75-151Q LW75-151D LW151-151D	H current range: 10 mA L current range: 1 mA
	LW301-151S	10m A
Accuracy	All models	±(0.5%RDG+0.3%FS) at 23°C±5°C
Measurement frequency	All models	Twice or more/sec.

2-9 DC Voltage Measurement

Item	
Resolution	100 mV/10 mV (Automatic range. Hysteresis: 90/100 V)
Accuracy	±(0.5%RDG+0.3%FS) at 23°C±5°C
Measurement frequency	Twice or more/sec.

2-10 DC Power Measurement

Item	Model	
Resolution	LW75-151Q LW75-151D LW151-151D	H current range: 100 mw L current range: 10 mw
	LW301-151S	100m W
Accuracy	All models	±(1%RDG + 0.6%FS) at 23°C±5°C, at constant current over 10%
Measurement frequency	All models	Twice or more/sec

2-11 Voltage Remote Sensing

Item	
Correction voltage	1 V, one way (Load input terminal voltage is between min. operating voltage and 150 V.)

2-12 External Contact Control

Item	
Main input ON/OFF	Main input is turned on by short-circuiting the contacts.
PRESET 1 to 4 selection	PRESET 1 to 4 is selected by short-circuiting the contacts.
Input select ON/OFF	Input select of each channel is turned on by short-circuiting the contacts.
Alarm IN/OUT	IN: Main input is turned off by short-circuiting the contacts. OUT: Contacts are short-circuited and main input is turned off when an alarm (OVA, OCA or OHA) occurs.

2-13 External Voltage Control

Item	
Input voltage	Set value (0 to 100%) in each discharge mode is adjusted with setting control knob according to external voltage between 0 and 10 V.
Set value updating time	CC mode: Real time, other mode: 2 seconds

2-14 Protection Functions

Item	
Out of input voltage range (OVA)	Occurrence condition: Input voltage over approx. 165 V Operation: Input select of channel where OVA occurs is turned off . Recovery condition: Canceling displayed alarm after eliminating occurrence condition.
Over-current (OCA)	Occurrence condition: 115% or more of rated input current Operation: Input select of channel where OCA occurs is turned off . Recovery condition: Canceling displayed alarm after eliminating occurrence condition.
Over-power (OPL)	Occurrence condition: 115% or more of rated input current Operation: Power limiting circuit of channel where OPL occurs works. Recovery condition: Eliminating occurrence condition.
Overheat (OHA)	Occurrence condition: Internal heat sink temperature is approx. 120°C. Operation: Main input is turned off . Recovery condition: Canceling displayed alarm after eliminating occurrence condition.
Reverse connection	Short circuiting with internal protection diode

2-15 Use Conditions, Size, etc.

Item	
Use temperature	0 to 40°C
Use humidity	20 to 85% (No condensation)
Storage temperature	-20 to 60°C
Storage humidity	20 to 85% (No condensation)
Source voltage	AC 100 V / 120V / 200V / 220V \pm 10%
Source frequency	50/60 Hz
Power consumption	Approx. 75 VA
Dielectric strength	Primary - casing: 1500 VAC for 1 minute Primary - secondary: 1500 VAC for 1 minute
Insulation resistance	Primary - casing, primary - secondary: 500 VDC, 10 M Ω
	Secondary - casing: 250 VDC, 5 M Ω
Cooling method	Forced cooling with fan
Outside dimensions	138 W x 124 H x 380 D mm
Maximum dimensions	138 W x 148 H x 458 D mm
Weight	Approx. 7.1 kg
Accessories	Rear ext. control connector: 1 CD-ROM(Instruction manual): 1 Three-core power cable Rear terminal cover Screws & nuts for rear terminal connection Adjusting screwdriver (only for models with control functions based on external voltages)

2-16 External Interface Control

Item	
GP-IB	Possible to read back set values and input values with IF-50GP.
USB	Possible to read back set values and input values with IF-50USB.

2-17 Communication Specifications of IF-50GP

Electrical specifications	Conforms to IEEE488-1978.
Mechanical specifications	Conforms to IEEE488-1978.
Interface function	SH1, AH1, T6,TE0, L3, LE0, SR0, RL0, PP0, DC0, DT0, & C0
Address setting	Address between 0 and 30 and listen-only function may be set freely when turning on power.
Transmission delimiter	CR.LF + EOI
Listener function	May set all input conditions of electronic loads under control.
Talker function	May detect all input statuses and settings of electronic loads under control.
Service request function	None

2-18 Communication Specifications of IF-50USB

Specifications	Conforms to USB Revision 1.1.
Connector shape	USB series B
Transmission rate	Full speed

3. PRECAUTIONS

3-1 Checking Source Voltage

- Use the LW series in the rated source voltage range.
- The rated source voltage of this unit is single-phase 100, 120, 200 or 220 VAC (voltage fluctuation: $\pm 10\%$, 50/60 Hz), which is set before shipment. Use the unit on the source voltage marked on the rear panel.

3-2 Connecting Power Cable

- Use the power cable suitable to the input voltage of this unit. Make sure that the power switch of the unit is shut off, and connect the power cable with the AC inlet.

3-3 Instruction on Connecting Input Terminals

- This is a multi-input electronic loading unit. Each input terminal is available in the floating condition. **However, series connection of input terminals is prohibited.**
- The input terminals of this unit are isolated from the casing. High voltage may be applied between the casing and input terminals of the unit, depending on the installation condition of the power supply. Be very careful.
- Be sure to turn off the main input of this unit when connecting the input terminals of the unit with the power supply. Connect load wires that sufficiently withstand the input current to the LW unit between the LW unit and power source. Use as short load wires as possible to minimize the resistance of the load wires.
- When using the sensing function, be sure to connect the + sensing terminal with + input terminal and the - sensing terminal with - input terminal of the same channel. Reverse connection or connection with another channel may cause malfunctioning or breakdown. Do not use unnecessarily long sensing wires between the LW unit and power source.

Twist the load wires and sensing wires, as the necessity requires. Twisting the wires reduces the influences of noises.

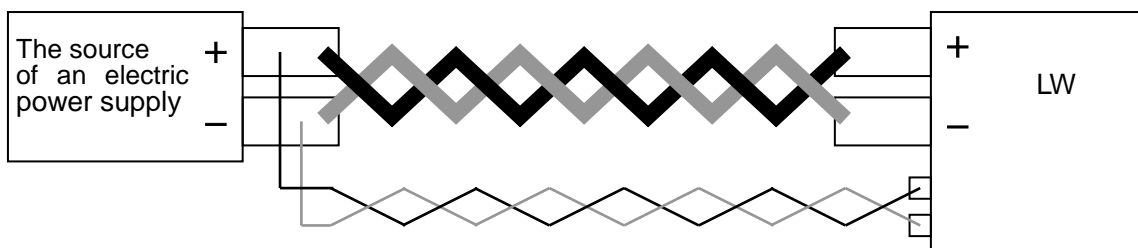

3-4 Installation Environment

- The allowable ambient temperature range when using this unit is 0 to 40°C. Do not use the unit at ambient temperature out of this range. If the unit is used at high ambient temperature and the built-in heat sink overheats, the internal overheat protector circuit works and an overheat alarm (OHA) occurs, turning off the main input. Do not block the air vents in the front and top panels or air outlet in the rear panel. Blocking them also causes internal overheat. **Leave enough spaces around the air vents and air outlet.**
- Hot air is blown out of the air outlet in the rear panel of the unit. If an object easily damaged by heat is placed behind the unit, it may possibly be deformed. If metal or the like is placed behind the unit, it is heated by exhaust air (hot air) from the rear panel, resulting in burn. Do not place any object (object easily damaged by heat, metal, etc., in particular) behind the unit. **Leave a space of 1.5 meter or more from the unit, if it is necessary to place some object.**
- This unit has an air inlet in the front part of the top panel. Blocking the air inlet may cause decrease of the performances, breakdown or OHA. **Never block the air inlet of the unit.**
- **Leave a space of 44 mm or more above the unit in order to prevent the air inlet from blocking**, when the unit is mounted on a rack, etc. Also achieve a condition of preventing warm air in the rack including exhaust air from flowing into the unit through the air inlet. (The rack must have no rear covers.)
- Do not use the unit in a dusty place or a place with much corrosive gas. Dust or corrosive gas may deteriorate the unit.

3-5 Current Limit Setting

- When the LW unit is used in a discharge mode other than the constant-current mode, large current flows from the power source to the unit, depending on the output conditions of the power source and setting of the LW unit, and the power source may become defective. Be sure to set the current limit of the LW series when the LW unit is used in a discharge mode other than the constant-current mode.

4. PANELS

4-1 Front Panel

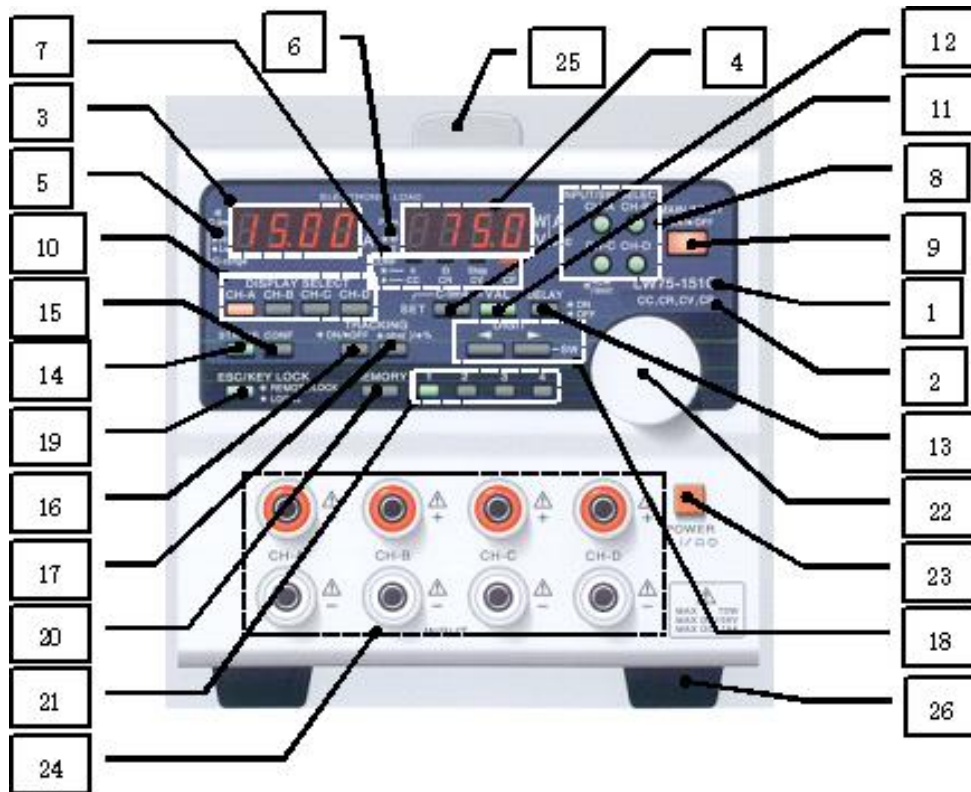

1. Model name

- One of the following model names is marked in this position.

LW75-151Q (75 W, 150 V, 15 A, four inputs), LW151-151D (150 W, 150 V, 30 A, two inputs), LW301-151S (300 W, 150 V, 30 A or 60 A, one input), and LW75-151D (75 W, 150 V, 15 A, two inputs) LW75-151Q

2. Discharge mode

- The discharge modes of the unit shown below are marked in this position.

(CC: constant-current mode, CR: constant-resistance mode, CV: constant-voltage mode, CP: constant-power mode)

- This unit provides operations in the discharge modes marked in this position.

3. A display unit (red): Four digits

- Displays the input current, set value and function setting characters of a channel with the orange DISCHARGE SELECT key lit.

4. V/W display unit (red): Four digits

- Displays the application voltage and power, set value, discharge mode, and function setting characters of a channel with the orange DISCHARGE SELECT key lit.

5. C-range indicator LED (lit in green)

C-lim indicator LED (blinking in green)

Current range indication function

- Stays on when the channel of the DISCHARGE SELECT key lit in orange is in the H current range.
Stays off when it is in the Low current range.

Current limitation status indication function

- Blinks when the channel of the DISCHARGE SELECT key lit in orange is in the current limitation status.

6. V/W indicator LED (lit in green)

P-lim indicator LED (blinking in green)

Voltage and power indication function

- Stays on when the power of the channel of the DISCHARGE SELECT key lit in orange is displayed on the V/W display unit. Stays off when the voltage is displayed.

Power limitation status indication function

- Blinks when the channel of the DISCHARGE SELECT key lit in orange is in the power limitation status.

7. Discharge mode/unit indicator LED (lit in red)

Discharge mode indication function

- The discharge mode LED of the channel of the DISCHARGE SELECT key lit in orange stays on when the CONF key is off.

Unit indication function

- Indicates the unit of the set value of the channel of the DISCHARGE SELECT key lit in orange when the CONF key is lit.

8. INPUT/SW SELECT key (lit in green/red)

ALARM/LIMIT indicator LED (lit in red/green)

Input select function

- Turns on or off the input of each channel.

Switching select function

- Turns on or off the switching select function of each channel.

NOTE: On the LW301-151S, this key provides the switching select function only, and this key is named "SW SELECT" key.

Alarm indication function

- The channel of the key blinking in red is in the alarm status.

Limit indication function

- The channel of the key blinking in green is in the limit status.

9. MAIN INPUT key (lit in red)

- Turns on or off the main input.

10. DISPLAY SELECT key (lit in orange, green or red)

Display channel selection function

- The key of the channel displayed on the A display and V/W display units is lit

Tracking setting status display function

- Displays the tracking setting.

NOTE: The LW301-151S does not have this function.

Alarm releasing function

- Releases the alarm status.

11. VAL key (lit in green)

- Enables to increase or decrease the set value of each discharge mode.

12. C-lim key (lit in green)

- Enables to increase or decrease the current limit value.

13. DELAY key (lit in green)

- Enables the delay function.

NOTE: The LW301-151S does not have this function or this key.

14. STATUS key

- Pressing this key brings the unit into the function setting mode.

15. CONF key (lit in green)

- Alternates the set value and input value displayed on the A display and V/W display units.

16. TRACKING ON/OFF key (lit in green)

- Turns on or off the tracking function.

NOTE: The LW301-151S does not have this function or this key.

17. TRACKING abs ()/% key (lit in green)

- Selects a tracking mode.

NOTE: The LW301-151S does not have this function or this key.

18. DIGIT/SW key

Set value digit changing function

- Changes the digit of the set value to be increased or decreased.

Switching select function

- Pressing an INPUT/SW SELECT key while holding the right DIGIT key turns on or off switching of the channel of the pressed INPUT/SW SELECT key.

NOTE: The LW301-151S does not have this function or this key.

19. ESC/KEY LOCK key (lit in green)

Escape function (Switching over from setting condition to non-setting condition)

- Changes the setting condition into the input value display condition.

Key locking function

- The keys are locked when this key is lit.

NOTE: This unit switches over from the setting condition to non-setting condition before it enters the key lock status.

Local function

- Operations on the front panel is enabled while this key is off.

20. MEMORY key

- Stores setting in the built-in EEPROM.

21. PRESET 1 to 4 keys

- Recalls the discharge mode and set value of the channel set to the PRESET key.

22. Rotary encoder

- Varies the set values of the channels and selects the contents of the function selection mode.

23. Power switch

- Turns on or off this unit.

24. Front input terminals

- Front input terminals of the unit. **Observe the current, voltage and power ranges marked on the panel.**
- These terminals are connected with the terminals on the rear panel. These front input terminals also carry voltage from the power supply when the input terminals on the rear panel are used, instead of these front input terminals. If the knobs of these front input terminals are removed, the metallic parts of the terminals are exposed and may cause electrocution. Thus, keep the knobs on the terminals even when these terminals are not used. The knobs of these terminals slide for enhanced handling efficiency. When the knob is slid forward, the metallic part of the terminal is exposed and is in danger of electrocution. Keep the knobs at the deep-set positions when power is applied to the unit by the power supply.

NOTE: The rated input current of the LW301-151S is 60 A. That of the model with the front input terminals is 30 A.

25. Handle

26. Rubber Shoes

4-2 Rear Panel

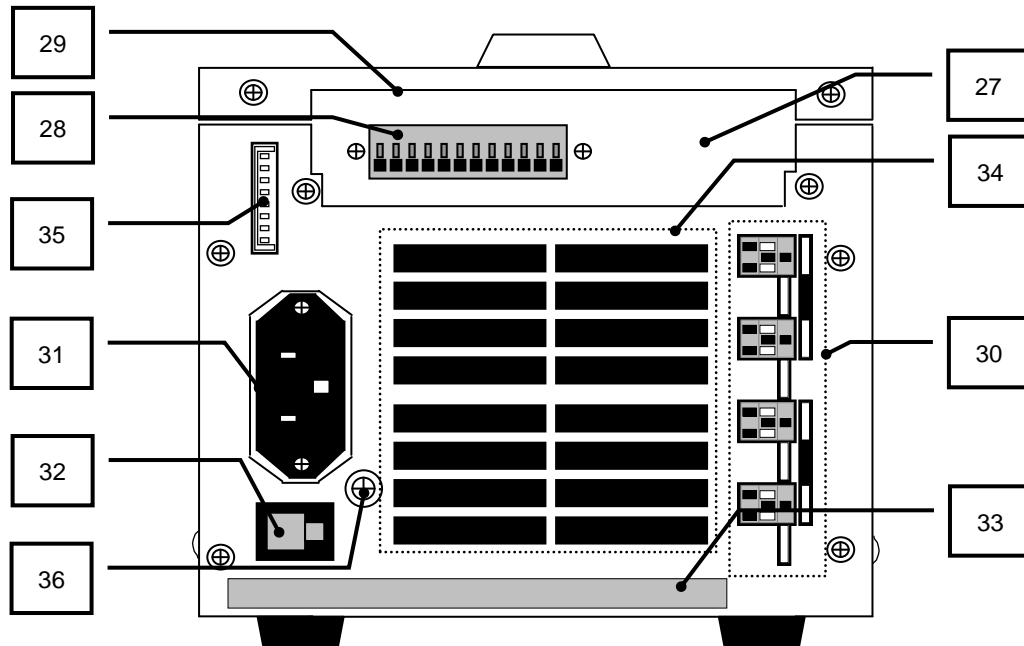

27. Optional board mount

- Mount the optional board IF-50GP or IF-50USB in this position.
- A dummy panel is mounted in this position of a model with no optional board. (The interface board is installed by option when the user places an order.)
- A model with the external voltage control function (factory option) has the external voltage control terminals. **On such a model, the optional interface board may not be mounted. It is impossible to mount the optional board (IF-50GP/USB) on a unit equipped with this connector.**

28. External voltage control terminals (on only a model with the factory-option external voltage control function)

- It is possible to set each discharge mode of the unit using external voltage (0 to 10 V).
- These terminals are connected with the negative input terminals. **Bring the external voltage into the floating condition when applying it to this unit.**

29. Optional board cover

- When mounting the optional board IF-50GP or IF-50USB, remove two screws from the right and left and open this cover.
- Detach this cover and set the voltage remote sensing selector switch, if the unit has that function.
- Detach this cover and adjust the set value of the unit with respect to the external voltage, if the unit has the external voltage control function.
- Be sure to close this cover before using the unit.** Otherwise, foreign matters may enter and the unit may break down.

30. Rear input terminals and voltage remote sensing terminals

- The rear input terminals and voltage remote sensing terminals of the unit. **Observe the current, voltage and power ranges marked on the panel.**
- The input terminals on the rear panel are connected with the terminals on the front panel. Voltage supplied by the power source is applied to these terminals even in the condition where the terminals on the front panel are used and these terminals are not used. These rear input terminals also carry voltage from the power supply when the input terminals on the front panel are used, instead of these rear input terminals. These rear input terminals have bare metallic parts and are in danger of electrocution. **Thus, keep the supplied rear terminal cover attached on the unit** even when these terminals are not used while power is applied to the unit by the power supply.

31. AC inlet

- Connect the AC power cable supplied with the unit, and supply commercial AC power to the unit. **Be sure to connect the grounding wire with the grounding terminal of the AC cable plug.**
- Input the voltage marked on the input rating plate on the rear panel.

32. Fuse holder

- The primary protection fuse is in this fuse holder.
- Use a fuse that meets the rating marked on the input rating plate on the rear panel if the fuse need be replaced.

33. Input rating plate

- The primary input voltage, fuse capacity, model name and serial number are marked on this plate.

34. Air outlet

- A built-in fan lets air out of the unit through this outlet.
- Hot air may be blown out through this air outlet. **Do not place any object within 1.5 meter from the rear panel of the unit.** Do not place any object easily damaged by heat, metal, etc., in particular, behind the unit. Do not place metal or the like, either, which may be heated to high temperature by exhaust air.
- Do not make the load cables, AC power cable and grounding wire connected to the rear panel exposed to hot exhaust air blown out from the unit.

35. External contact control connector : J1

- Used for external contact control. Short circuiting these connectors enables turning on/off of the main input, PRESET selection, turning on/off of the INPUT selector and alarm signal input/output.
- These connectors are connected with the internal circuit of the unit. Be sure to use these connectors in the floating condition.

36. Grounding screw

- Connect a grounding wire with this screw, if it is impossible to ground the unit using the plug of the three-core AC power cable supplied with the unit.

4-3 Optional Board Mount

The optional board mount is located at the top of the rear panel with the optional board mount cover removed.

- NOTE:**
- 1) Stop the electric power supply from the source of on electric power supply before this operation.
 - 2) This mount is above the heat sink. In operation, the heat may be hot and accordingly this mount may be hot. Cool down this mount sufficiently before using it.
 - 3) Attach the optional board mount cover immediately after using this mount. After the electric power supply from the source of an electric power supply to this machine attaches an option board attachment lid, please be sure to carry out it.

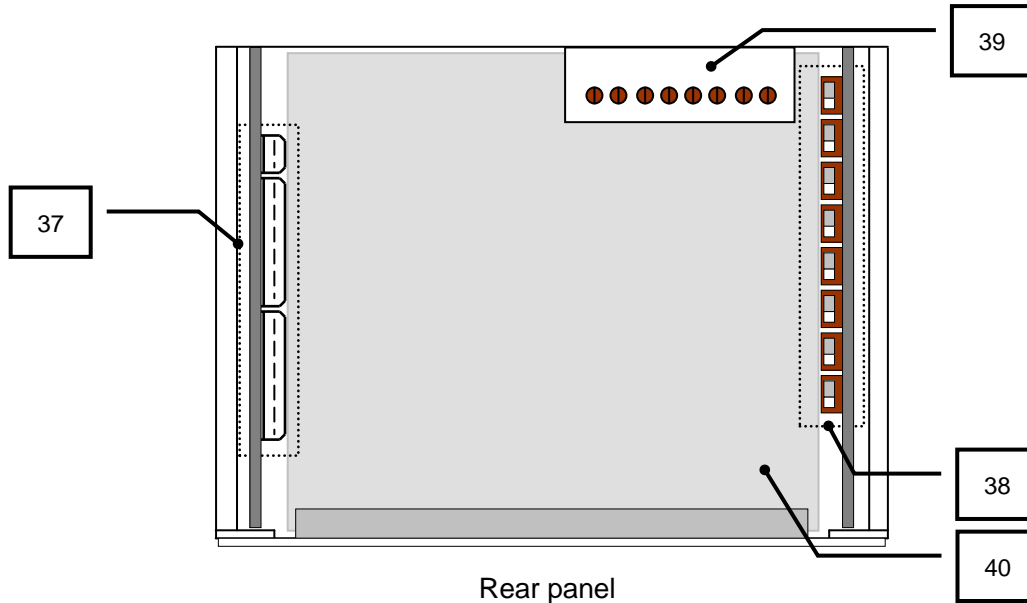

37. Optional board connectors

- These are the exclusive connectors for the optional boards IF-50GP and IF-50USB.
- These connectors are connected with the internal circuit of the unit. Be very careful not to let any foreign matters (conductors such as metal) into the unit. If such matters enter the unit, the unit may break down.

38. Voltage remote sensing selector switches

- The voltage remote sensing point of the unit may be selected at three positions: Outside of the unit, with the front terminals, and with the rear terminals.
- A model with no voltage remote sensing connectors on the rear panel does not have these selector switches.

39. External voltage control knobs (on only models with the factory-option external voltage control functions)

- Adjusts the set value of the unit with respect to the external voltage.

40. Insulation sheet

- Prevents foreign matters from entering the unit.
- The heat sinks are under this sheet and may be hot, depending on the operation conditions. As far as possible keep from touching this sheet to avoid burn, etc.

5. BEFORE USING UNIT

5-1 Position of Voltage Remote Sensing Selector Switches

Be sure to disconnect the AC power cable from the unit before using these switches. Cut off electric power from the power supply to the unit as well.

- Detach the optional board mount cover. Set the voltage remote sensing selector switches.
- The voltage remote sensing selector switches are arranged as shown below, provided the front panel is on the right and the rear panel is on the left.

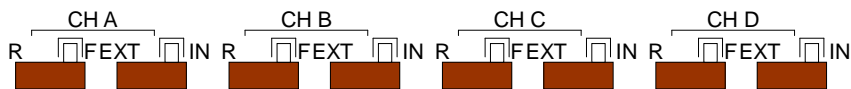

- Two selector switches are used per channel. The switch on the right is used for external / internal selection. The switch on the left is used for front / rear selection. A channel is marked above two selector switches. Channels A, B, C and D are arranged from the left.
- When using the voltage remote sensing function, the voltage remote sensing terminals must be the sensing point. In this case, set the right switches only to the EXT (left) position. The left switches may be set to either position.
- When the power supply is connected with the input terminals on the rear panel without using the voltage remote sensing function, the rear terminals must be the sensing point. In this case, set the right switches to the IN (right) position and the left switches to the R (left) position.
- When the power supply is connected with the input terminals on the front panel without using the voltage remote sensing function, the front terminals must be the sensing point. In this case, set the right switches to the IN (right) position and the left switches to the F (right) position.

NOTE: 1) LW75-151D does not have a switch for channel C and channel D.

2) The LW301-151S has a channel B/C/D selector switch.

3) Models with no front input terminals do not have the left selector switches (front/rear selector switches).

4) If a selector switch is set at an inaccurate position, lower voltage than the actual voltage is displayed on the unit. Such inaccurate setting may cause breakdown or over-discharge of the batteries if used as the power source. Set each selector switch to the right end or left end.

5) The same phenomena may occur if the use method is different from the setting of the selector switches. Set the selector switches to the proper position according to the application.

6) LW151-151D does not have switches for channel B and channel D.

A switch displayed as CH C is for channel B.

5-2 Connection of Power Supply

- Connect the power supply with the input terminal of the unit firmly using crimp-style terminals, etc.
- Connect load wires that sufficiently bear the current capacity between the LW unit and power source.
- For safety, be sure to confirm that the MAIN INPUT key of the unit is off before connecting or disconnecting the cable. Turn off the output of the power source as well.
- This unit is a multi-input type electronic loading unit. If the input terminals of the unit are connected in series with a single power supply, the voltage applied to the input terminals become unbalanced, resulting in malfunctioning or breakdown of the unit. Do not connect the input terminals of the unit in series with a single power supply.
- This unit is a multi-input type electronic loading unit capable of voltage remote sensing. Connect the input terminals and voltage remote sensing terminals to the same channel. Do not mistake the polarity. Connecting the voltage remote sensing connectors with the input terminals of another channel or the input terminals of wrong polarity may result in malfunctioning or breakdown of the unit.

5-2-1 Connecting with input terminals on front panel

NOTE: If the knobs are removed from the front input terminals, the metallic parts are exposed.

Be sure to keep the knobs on the terminals. Besides, the knobs of these terminals have sliding structures. When the knob is slid forward, the metallic part of the terminal is exposed. Keep the knobs at the deep-set positions when power is applied to the unit.

1. Turn off the MAIN INPUT key of the unit.
2. Disconnect the knobs from the front input terminals.
3. Connect power supplying wires to the front input terminals.
4. Fix the power supplying wires to the input terminals with the knobs removed in step 2.

NOTE: If the knob of the terminal is slid forward, the knob may be easily handled (rotated). (See the figures below.) After operation, be sure to press the knob against the front panel.

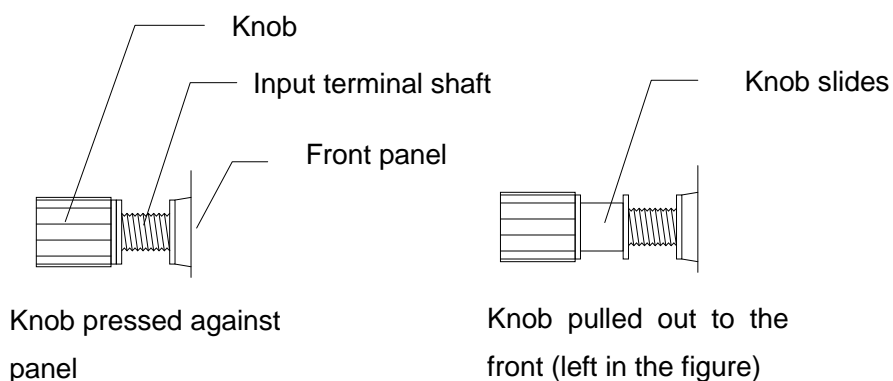

5-2-2 Connecting with input terminals on rear panel

NOTE: The input terminals on the rear panel have bare metallic parts. Be sure to keep the supplied rear terminal cover on them.

1. Turn off the MAIN INPUT key of the unit.
2. Remove the screws above and on the lower right of the rear input terminals. (See the figure below.)
3. Pass the power supplying wires and voltage sensing wire to be connected with the unit through the rear input terminal cover supplied with the unit.
4. Connect the power supplying wires with the rear input connectors using the screws and nuts supplied with the unit. Also connect the voltage remote sensing wire with the voltage remote sensing connector on the unit. Press the white part of the terminal and insert the conductor of the voltage remote sensing connector with the sheath removed into the terminal. (See the figure below.)
5. Fix the rear input terminal cover with the screws removed in step 2 as shown below.

NOTE: 1) If the voltage remote sensing function is not used, it is unnecessary to connect the voltage remote sensing connector to the voltage remote sensing terminal.

- 2) Insert the voltage remote sensing connector into the left hole in the voltage remote sensing connector.

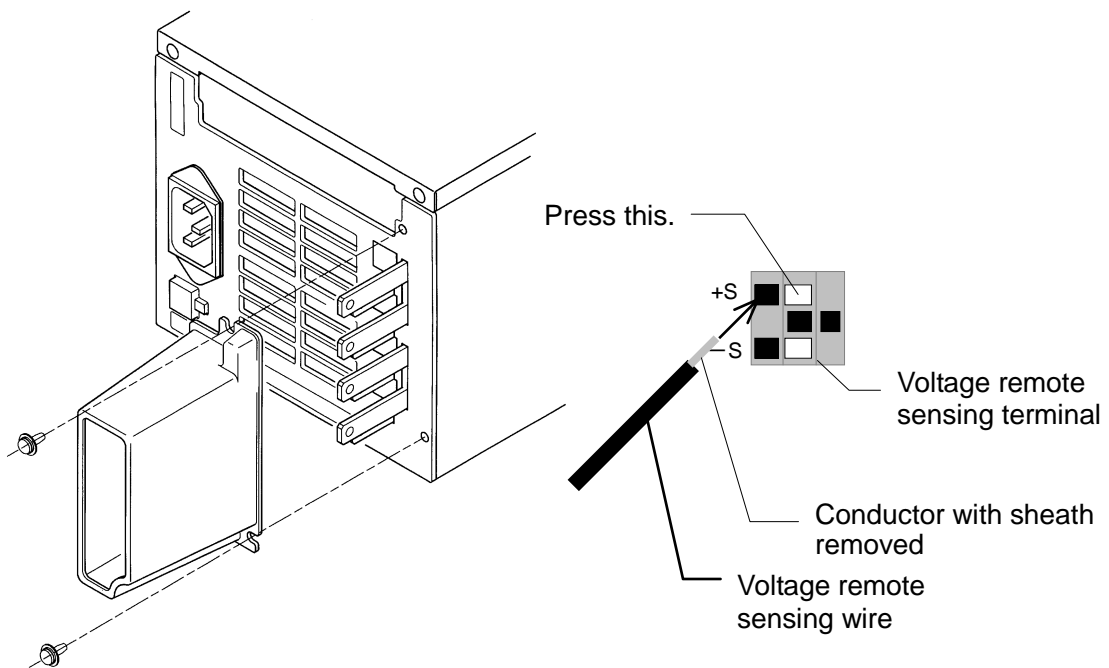

5-3 Turning On Power

5-3-1 Display when turning on power

- Connect the AC power cable supplied with the unit properly, and throw the power switch. Until the unit enters the normal operating condition, the numbers and characters shown in 1 to 5 below are displayed on the A and V/W display units. The numbers and characters shown in 1 to 6 below are displayed on them when the power switch is thrown while pressing the ESC/KEY LOCK key.

1. A display unit: 0000 V/W display unit: 0000 ... These numbers are displayed for approx. 3 seconds after throwing the power switch.

2. A display unit: 1dno V/W display unit: - - - 1 ... The ID number of the LW unit is displayed then.

↑
ID number

Model	ID
LW75-151Q	1
LW151-151D	2
LW301-151S	3
LW75-151D	4
LW301-151S with front input terminals	5

3. A display unit: r0Ur V/W display unit: - 0.00 ... The program version number of the unit is displayed.

4. A display unit: IF- V/W display unit: - - - - ... The mounting condition of the interface board (option) is displayed.

A display unit: - - - -	... No interface board is mounted.
A display unit: 506P	... Interface board IF-50GP is mounted.
A display unit: 50u5	... Interface board IF-50US is mounted.

5. A display unit: r0Ur V/W display unit: - 0.00 ... The program version number when the interface unit is mounted

6. A display unit: cH-A V/W display unit: crUP ... The discharge mode of each channel is displayed.

CP mode available.

CV mode available

CR mode available

CC mode available

Input channel

5-3-2 Setting when turning on power and storing setting

• The table below shows the default setting and the setting after initializing the memory.

Item	Initial setting	Savable or not
INPUT SELECT key	All ON	○
SW SELECT key	All OFF	○
MAIN INPUT key	OFF	×
DISPLAY/STATUS key	Channel A key is lit in orange.	○
C-lim key	OFF	×
VAL key	ON	×
DELAY key	OFF	×
CONF key	OFF	×
TRACKING ON/OFF key	OFF	○
TRACKING ABS (/)% key	OFF	○
ESC/KEY LOCK key	OFF	×
PRESET key	PRESET 1 is lit in green.	○
Current range of each channel	H	○
Current limit of each channel	Max. current	○
CC set current of each preset	Min. current	○
CR set resistance of each preset	Max. resistance	○
CV set voltage of each preset	Min. voltage	○
CP set voltage of each preset	Min. power	○
Switching setting method	Frequency & duty	○
Display time-out time	3 minutes	○
Rear contact function	PRESET switching selection	○

5-4 Alarm

5-4-1 EAR (External alarm)

This alarm occurs when pins 1 and 2 of the external contact control connector (J1) on the rear panel are short-circuited. The following shows the indication of the unit when this alarm occurs.

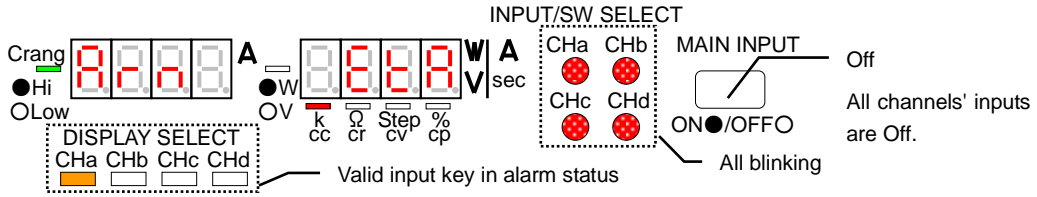

5-4-2 OHA (Overheat alarm)

This alarm occurs when the heat sink in the unit overheats since the air inlet in the top panel is blocked, the air outlet in the rear panel is blocked, the unit is operated at high temperature over the allowable temperature range, the power exceeds the rated power, etc. The following shows the indication of the unit when this alarm occurs.

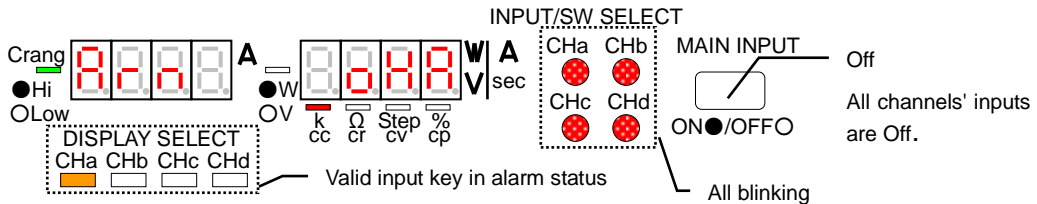

5-4-3 OVA (Over-voltage application alarm)

This alarm occurs when voltage over the rated voltage is applied to the input terminals of the unit. The following shows the indication of the unit when this alarm occurs.

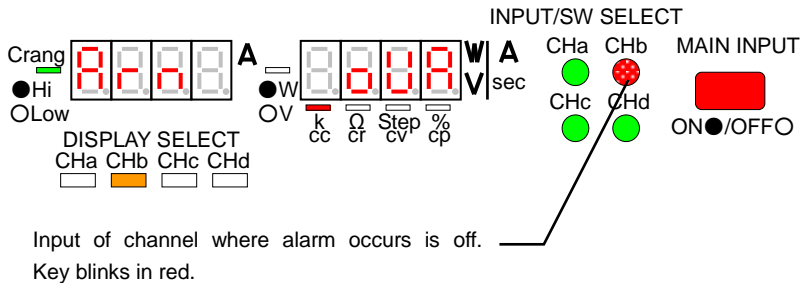

5-4-4 OCA (Over-current input alarm)

This alarm occurs when current over the rated current is applied to the input terminals of the unit. The following shows the indication of the unit when this alarm occurs.

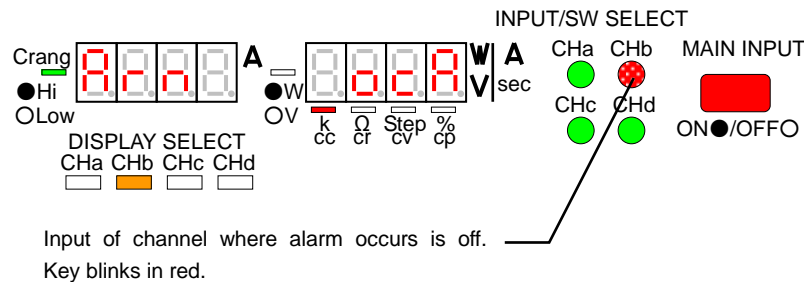

5-5 Limit Functions

5-5-1 Over-power limit (OPL)

This function works when the input power of the unit exceeds 115% of the rated power. The following shows the indication in this limit status.

NOTE: If operation continues in this status, an OHA may occur.

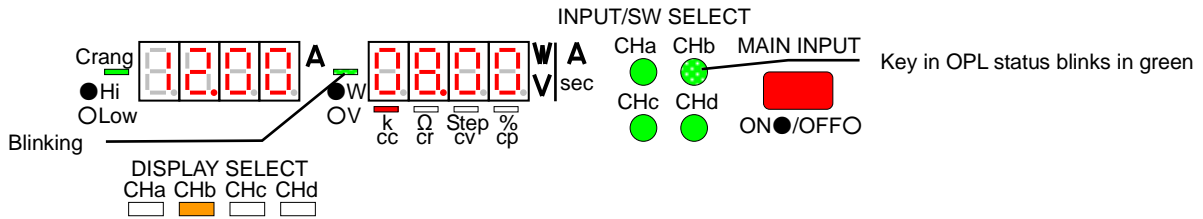

5-5-2 Current limit (CL)

This function works when the input current of the unit reaches the preset current limit. The following shows the indication in this limit status.

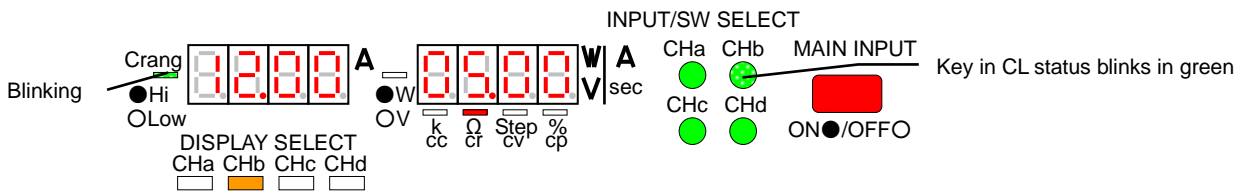

5-6 Replacement of Power Fuse

- The input voltage of this unit is set to 100, 120, 200 or 220 VAC before shipment. Use a fuse that meets the rating marked on the rating plate on the rear panel if the fuse need be replaced.

CAUTION

Be sure to disconnect the power cable or open the breaker on the distribution panel on the supply side before replacing the fuse.

Use the fuse having the characteristics and capacity shown below. If a fuse out of the

Replacing Power Fuse

- Make sure that the power cable is disconnected from the unit.
- Take out the fuse from the fuse holder on the rear panel. Replace it with an appropriate fuse.

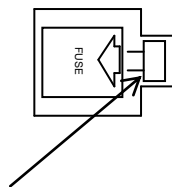

Press this part in the direction of the arrow to take out the fuse. Insert a new fuse until a click sound is heard.

○ Fuse Capacity and Characteristics

Source voltage	Fuse rating
AC100V	250V 1.25A
AC120V	250V 1.25A
AC200V	250V 0.4A
AC220V	250V 0.4A

Use a slow-blow fuse.

6. FUNCTIONS AND OPERATION PROCEDURES

6-1 Operation Method Selecting Function

This unit provides three selectable operation methods shown below.

1. Switching method selection:

It is possible to select two switching time setting methods: Frequency and duty, and Ta time and Tb time.

2. Time-out time selection:

It is possible to set the time-out time. Display changes into the normal display if no key operations are done for the preset time-out time.

3. Rear contact function selection:

It is possible to select either the PRESET key functions or the INPUT SELECT key functions.

6-1-1 Selecting operation method

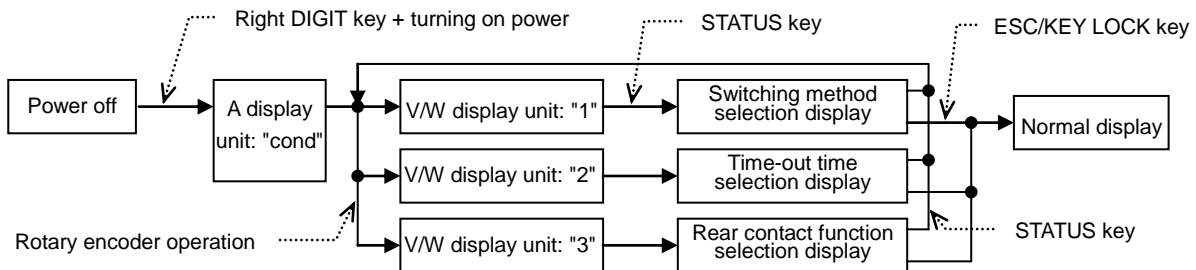

- When power is turned on while depressing the right DIGIT key, "cond" and "1" are displayed on the A and V/W display units, respectively.
- "1" displayed on the V/W display unit changes into 2, 3 and then 1 when rotary encoder is rotated in the condition shown in step 1.
- The switching method selection screen appears when the STATUS key is pressed in the condition where "1" is displayed on the V/W display unit. The time-out time selection screen appears when the STATUS key is pressed in the condition where "2" is displayed on the V/W display unit. The rear contact function selection screen appears when the STATUS key is pressed in the condition where "3" is displayed on the V/W display unit.

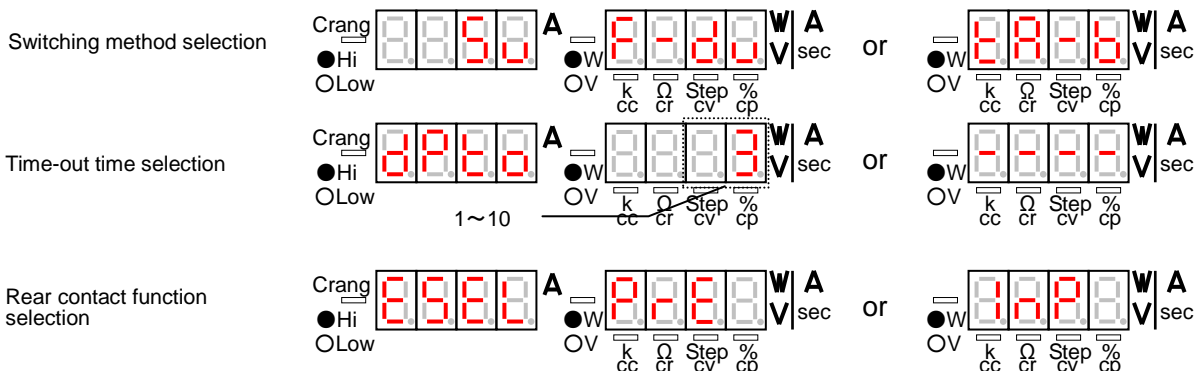

6-1-2 Switching method selection

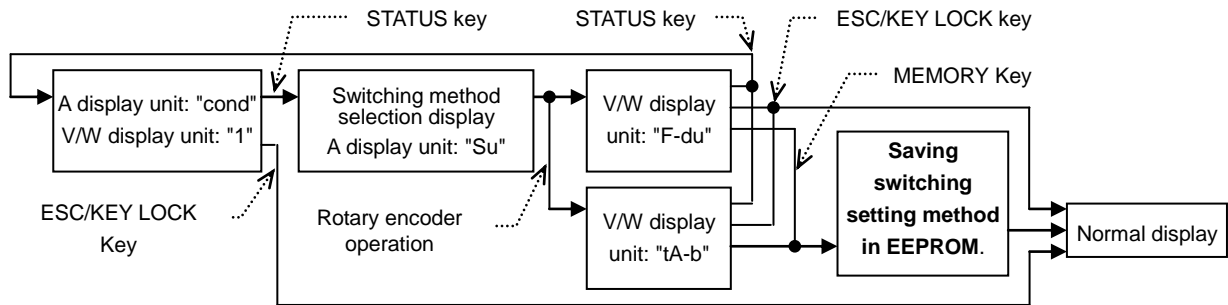

1. "F-du", "tA-b", "F-du" and so forth are displayed in sequence on the V/W display unit when the rotary encoder is rotated in the condition where the switching method selection screen is displayed ("Su" on the A display unit and "F-du" or "tA-b" on the V/W display unit).
2. When the MEMORY key is pressed in step 2, the A and V/W display units are filled with "-", the other key switches go out, and the switching time setting method is saved in the built-in EEPROM. The saved setting method is "frequency and duty" if "F-du" is displayed on the V/W display unit before pressing the MEMORY key or "Ta time and Tb time" if "tA-b" is displayed on the V/W display unit. When the setting method is saved in the EEPROM, the unit runs in the saved switching time setting method, and the normal display is restored.

NOTE: If the normal display is restored after pressing the ESC/KEY LOCK key, the switching time setting method selected here is not saved in the built-in EEPROM.

6-1-3 Time-out time selection

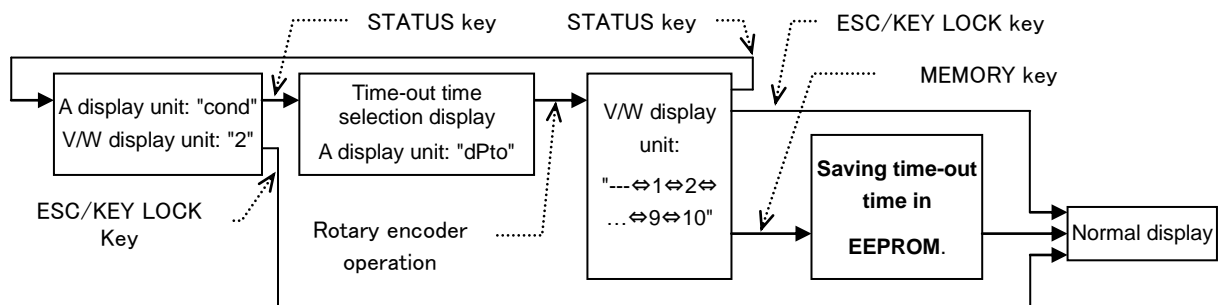

1. "- - - -" <----> 1 <----> 2 ... 9 <----> 10 are displayed in sequence on the V/W display unit when the rotary encoder is rotated in the condition where the time-out time selection screen is displayed ("dPto" on the A display unit and one of "- - - -", 1, 2 ... 9, and 10" on the V/W display unit).
2. When the MEMORY key is pressed in step 3, the A and V/W display units are filled with "-", the other key switches go out, and the time-out time is saved in the built-in EEPROM. The saved time-out time is one minute if "1" is displayed on the V/W display unit before pressing the MEMORY key, two minutes if "2" is displayed, ten times if "10" is displayed, or no time-out if dashes ("-") are displayed. When the time-out time is saved in the EEPROM, the unit runs according to the saved time-out time, and the normal display is restored.

NOTE: If the normal display is restored after pressing the ESC/KEY LOCK key, the time-out time selected here is not saved in the built-in EEPROM.

6-1-4 Rear contact function selection

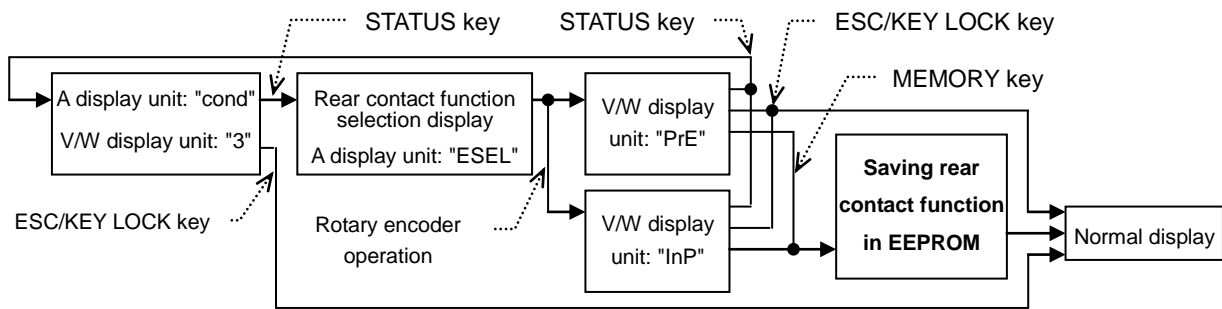

1. "PrE" --> "InP" --> "PrE" and so forth are displayed in sequence on the V/W display unit when the rotary encoder is rotated in the condition where the rear contact function selection screen is displayed ("ESEL" on the A display unit and "PrE" or "InP" on the V/W display unit).
2. When the MEMORY key is pressed in step 3, the A and V/W display units are filled with "-", the other key switches go out, and the rear contact function is saved in the built-in EEPROM. The saved setting method is "PRESET key selecting function through the rear contacts" if "PrE" is displayed on the V/W display unit before pressing the MEMORY key or "INPUT SELECT key selecting function through the rear contacts" if "InP" is displayed on the V/W display unit. When the rear contact function is saved in the EEPROM, the unit runs using the saved rear contact function, and the normal display is restored.

NOTE: If the normal display is restored after pressing the ESC/KEY LOCK key, the rear contact function selected here is not saved in the built-in EEPROM.

6-2 Function Setting Mode

This unit is capable of setting the following four parameters individually.

1. Delay time

The delay time of each channel may be set. However, the LW301-151S does not have this function.

2. Tracking operation

The tracking operation of each channel may be set. However, the LW301-151S does not have this function.

3. Discharge mode

The discharge mode of each PRESET of each channel may be set.

4. Switching time

The frequency and duty may be set when the "frequency and duty" switching method is selected.

The Ta time and Tb time may be set when the "Ta time and Tb time" switching method is selected.

6-2-1 Function setting mode operation

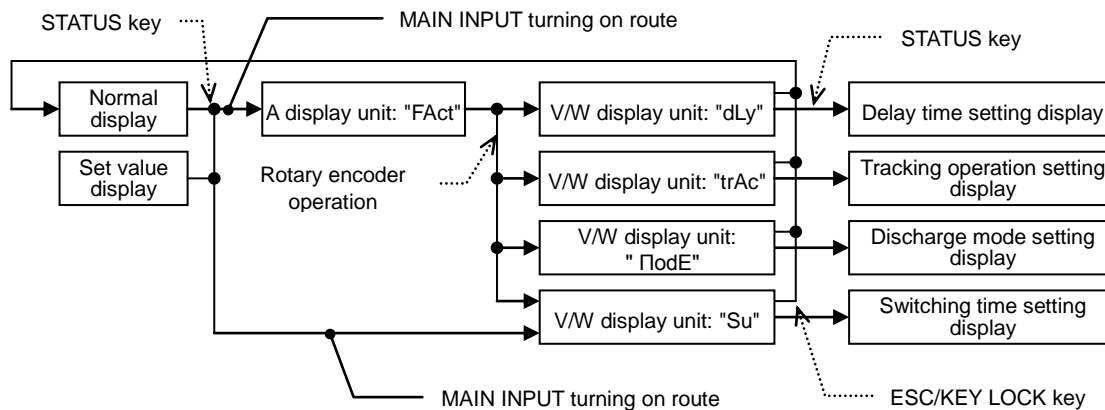

1. When the STATUS key is pressed in the condition where the MAIN INPUT is off, "FAct" and "----" are displayed on the A and V/W display units, respectively.
2. When the rotary encoder is rotated clockwise in the condition where "FAct" is displayed on the A display unit, the characters displayed on the V/W display unit change in the order of "----" → "dLy" → "trAc" → "ΠodE" → "Su" → "dLy". When the rotary encoder is rotated counterclockwise, the characters change in the order of "Su" → "ΠodE" → "trAc" → "dLy" → "Su".
3. When the STATUS key is pressed in step 2, the following setting screen appears.
 - Delay time setting screen when "dLy" is displayed on the V/W display unit
 - Tracking setting screen when "trAc" is displayed on the V/W display unit
 - Discharge mode setting screen when "ΠodE" is displayed on the V/W display unit
 - Switching time setting screen when "Su" is displayed on the V/W display unit

NOTE: On the LW301-151S, "ΠodE" and "Su" are only displayed on the V/W display unit. "dLy" or "trAc" is not displayed on it.

When MAIN INPUT is on, it is impossible to display the delay time setting screen or tracking setting screen or set the discharge mode.

6-2-2 Delay time setting

Set the time of turning on or off the input of each channel by turning on or off the main input.

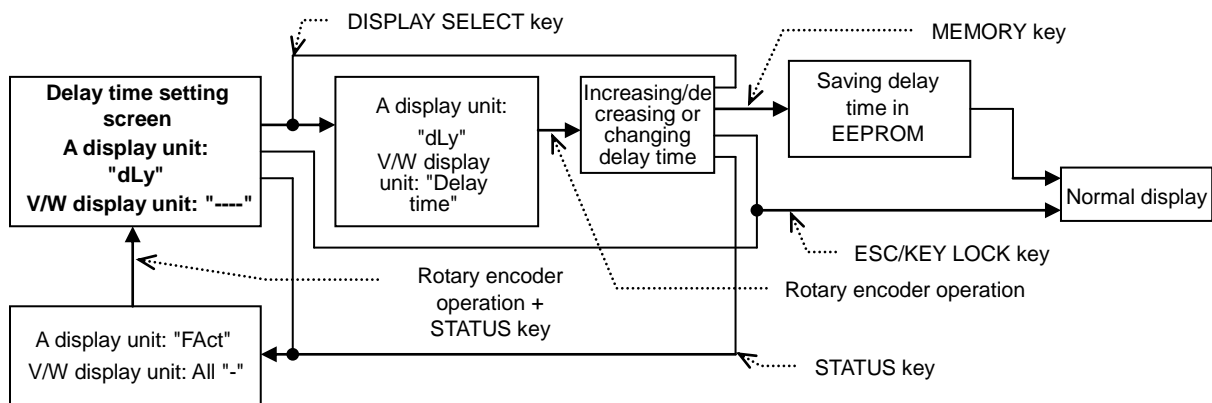

1. When the DISPLAY SELECT key of a channel whose delay time should be set in the condition where the delay time setting screen is displayed, the pressed DISPLAY SELECT key is lit in green. The delay time is displayed on the V/W display unit in four digits, the lowest digit of which represents 0.01 second. The lowest digit of the delay time blinks at this time. Hold the DISPLAY SELECT key lit in green and press unlit DISPLAY SELECT keys to increase or decrease the delay time of several channels simultaneously. This operation may turn on several DISPLAY SELECT keys in green.
2. In the condition shown in 1, move the blinking digit of the delay time with the DIGIT key and set the delay time with the rotary encoder. The delay time setting range is 0.00 to 10.00 seconds.
3. Repeat steps 1 and 2 to set the delay time of the other channels.
4. "- - -" are displayed on the A and V/W display units (for approximately three seconds) when the MEMORY key is pressed in the condition shown in step 3. The delay time of the channel(s) set here is written in the built-in EEPROM and operation is complete.

NOTE: 1) The STATUS, ESC/KEY LOCK, DISPLAY SELECT, MEMORY and DIGIT keys and the rotary encoder are only functional in this setting.

- 2) Even though the ESC/KEY LOCK key is pressed to finish this setting, the set delay time is changed. However, the set delay time is not written in the built-in EEPROM. Thus, the delay time set in this setting is invalidated when the unit is turned off.

It is impossible to set the delay time of each channel independently if all DISPLAY SELECT keys are lit in green (i.e., delay time of all channels is set simultaneously) in step 1. (DISPLAY SELECT key operation is invalid.)

6-2-3 Tracking operation setting

Select whether to execute tracking of each channel.

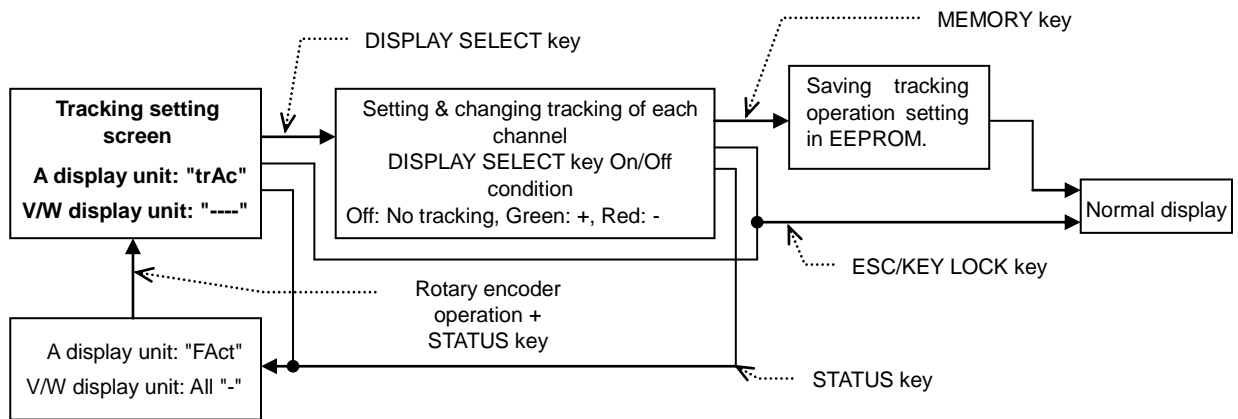

All DISPLAY SELECT keys are lit in the currently set tracking conditions. The table below shows the relationship between the key conditions and tracking setting.

Key condition	Increasing/decreasing the tracking set value
Off	No tracking setting. Set value is not increased or decreased.
Lit in green	+ tracking. Rotating rotary encoder clockwise increases set value.
Lit in red	- tracking. Rotating rotary encoder clockwise decreases set value.

- When the DISPLAY SELECT key of the channel whose tracking setting should be changed is pressed in the condition where the tracking setting screen is displayed, the pressed DISPLAY SELECT key changes as shown below:
Condition before pressing the key ... Off → Lit in green → Lit in red → Off → Lit in green → Lit in red
Change the tracking setting of the channel.
- Press the DISPLAY SELECT key of another channel to change its tracking setting.
- "- - -" are displayed on the A and V/W display units (for approximately three seconds) when the MEMORY key is pressed in the condition shown in step 2. The tracking conditions of all channels set here are written in the built-in EEPROM and operation is complete.

NOTE: 1) The STATUS, ESC/KEY LOCK, DISPLAY SELECT and MEMORY keys are only functional in this setting.

- Even though the ESC/KEY LOCK key is pressed to finish this setting, the set tracking conditions are changed. However, the set tracking conditions are not written in the built-in EEPROM. Thus, the tracking conditions set in this setting is invalidated when the unit is turned off.

6-2-4 Discharge mode setting

One-time operation sets the discharge mode of one PRESET, though it sets the discharge modes of all channels. Thus, in discharge mode setting, turn on the PRESET key whose discharge mode should be set before pressing the STATUS key.

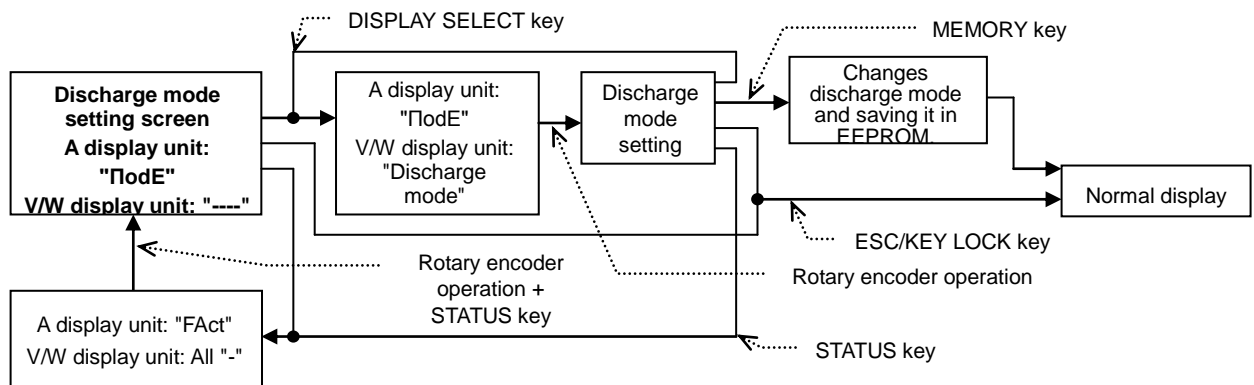

1. When the DISPLAY SELECT key of the channel whose discharge mode should be changed in the condition where the discharge mode setting screen is displayed, the pressed DISPLAY SELECT key is lit in green. The currently set discharge mode is displayed on the V/W display unit.
2. The characters displayed on the V/W display unit change when the rotary encoder is operated in the condition shown in step 1. The table below shows the relationship between the displayed characters and discharge modes.

	Displayed characters	Discharge mode		Displayed characters	Discharge mode
1	H - c c	CC in H current range	7	H - P L	CP in H current range, L voltage range
2	L - c c	CC in L current range	8	H - P H	CP in H current range, H voltage range
3	H - c r	CR in H current range	9	L - P L	CP in L current range, L voltage range
4	L - c r	CR in L current range	10	L - P H	CP in L current range, H voltage range
5	H - c V	CV in H current range	11	S H r t	Short-circuit
6	L - c V	CV in L current range			

3. When the VAL key is pressed in step 2, "E" is displayed at the third digit of the V. W display unit, indicating that external voltage control is selected. When the VAL key is pressed again, "E" displayed at the third digit of the V. W display unit disappears and external voltage control is canceled.
4. Repeat steps 1 and 3 to set the discharge modes in other channels.
5. When the MEMORY key is pressed after setting the discharge mode, "- - -" is displayed in the A and V. W display units (for approximately three seconds). In this period, the discharge modes of all lit PRESET channels set above are written in the EEPROM and this operation ends.

NOTE: 1) The STATUS, ESC/KEY LOCK, DISPLAY SELECT and MEMORY keys and the rotary encoder are only functional in this setting.

2) The set values of the channels whose discharge modes are changed here are the minimum current (CC mode), maximum resistance (CR mode), minimum voltage (CV mode) and minimum power (CP mode). Press the ESC/KEY LOCK key to stop this operation. The discharge modes of the channels are not changed in this case.

3) It is impossible to select external voltage control when the unit is in the SHrt discharge mode.

6-2-5 Switching time setting method 1

Set the duty and frequency in switching.

This operation is disabled unless the "frequency and duty" switching time setting method is selected.

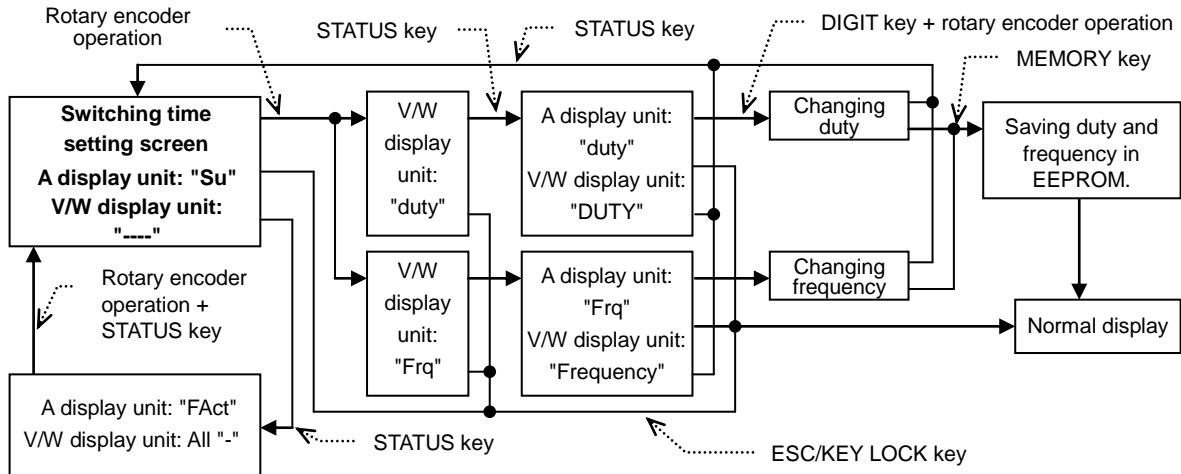

1. When the rotary encoder is rotated clockwise in the condition where the switching time setting screen is displayed, "dUty" and "Frq" are displayed on the V/W display unit alternately.
2. When the STATUS key is pressed in the condition where "dUty" is displayed on the V/W display unit, "duty" is displayed on the A display unit and the currently set duty is displayed on the V/W display unit. The lowest digit of the duty blinks. Move the blinking digit to an intended digit of the duty with the DIGIT key and set the duty with the rotary encoder. The duty setting range is between 5 and 95%.
3. When the STATUS key is pressed in the condition where "Frq" is displayed on the V/W display unit, "Frq" is displayed on the A display unit and the currently set frequency is displayed on the V/W display unit. The lowest digit of the frequency blinks. Move the blinking digit to an intended digit of the frequency with the DIGIT key and set the frequency with the rotary encoder. The frequency setting range is between 1 to 500 Hz.
4. "- - -" are displayed on the A and V/W display units (for approximately three seconds) when the MEMORY key is pressed in the conditions shown in steps 2 and 3. The duty and frequency set here are written in the built-in EEPROM and operation is complete.

NOTE: 1) The STATUS, ESC/KEY LOCK, MEMORY and DIGIT keys and the rotary encoder are only functional in this setting.

2) It is possible to turn off the MAIN INPUT key during this operation with the MAIN INPUT key lit. However, it is impossible to turn on the MAIN INPUT key. To turn on the MAIN INPUT key, complete this operation.

3) Even though the ESC/KEY LOCK key is pressed to finish this setting, the set duty and frequency are changed. However, the set duty and frequency are not written in the built-in EEPROM. Thus, the duty and frequency set in this operation are invalidated when the unit is turned off.

6-2-6 Switching time setting method 2

Set the Ta time and Tb time in switching.

This operation is disabled unless the " Ta time and Tb time" switching time setting method is selected.

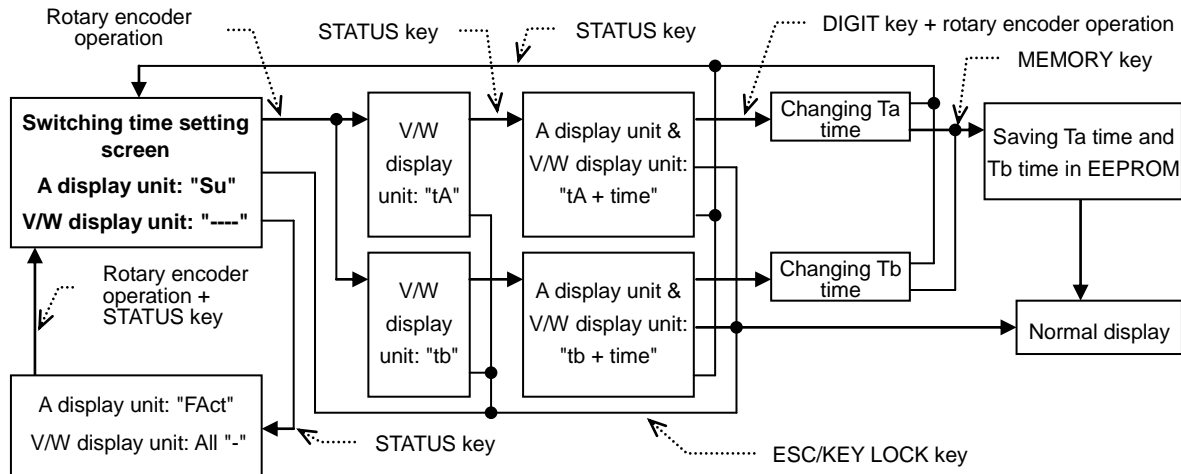

1. When the rotary encoder is rotated clockwise in the condition where the switching time setting screen is displayed, "tA" and "tb" are displayed on the V/W display unit alternately.
2. When the STATUS key is pressed in the condition where "tA" is displayed on the V/W display unit, the currently set Ta time is displayed on the A and V/W display units. The lowest digit of the Ta time blinks. Move the blinking digit to an intended digit of the Ta time with the DIGIT key and set the Ta with the rotary encoder.
3. When the STATUS key is pressed in the condition where "tb" is displayed on the V/W display unit, the currently set Tb time is displayed on the A and V/W display units. The lowest digit of the Tb time blinks. Move the blinking digit to an intended digit of the Tb time with the DIGIT key and set the Tb time with the rotary encoder.
4. "- - -" are displayed on the A and V/W display units (for approximately three seconds) when the MEMORY key is pressed in the conditions shown in steps 2 and 3. The Ta time and Tb time set here are written in the built-in EEPROM and operation is complete.

NOTE: 1) The STATUS, ESC/KEY LOCK, MEMORY and DIGIT keys and the rotary encoder are only functional in this setting.

2) It is possible to turn off the MAIN INPUT key during this operation with the MAIN INPUT key lit. However, it is impossible to turn on the MAIN INPUT key. To turn on the MAIN INPUT key, complete this operation.

3) Even though the ESC/KEY LOCK key is pressed to finish this setting, the Ta time and Tb are changed. However, the set Ta time and Tb time are not written in the built-in EEPROM. Thus, the Ta time and Tb time set in this operation are invalidated when the unit is turned off.

6-2-7 Changing input voltage display and input power display

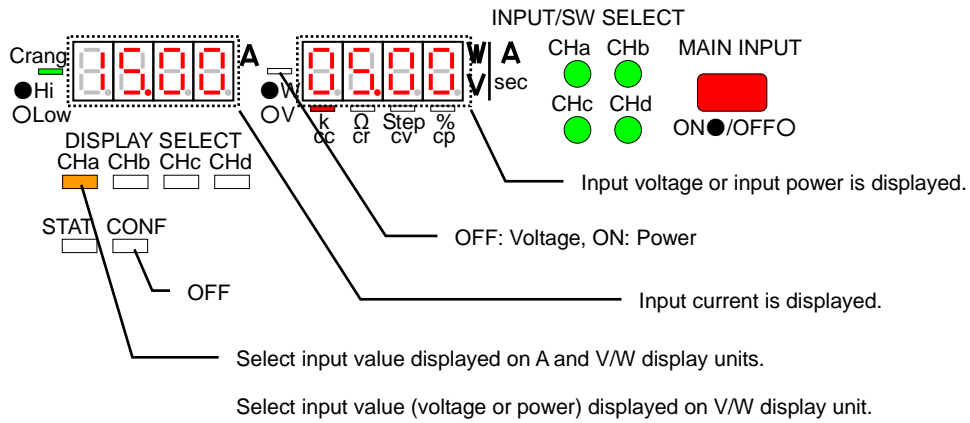

- Press a DISPLAY SELECT key in the condition where the CONF key is off. The pressed key goes on in orange and the input value of that channel is displayed on the A and V/W display units.
- Every press of the DISPLAY SELECT key lit in orange turns on and off the LED of the V/W display unit alternately. When the LED is off, the input voltage is displayed on the V/W display unit. When the LED is lit, the input power is displayed on the V/W display unit.

6-2-8 Changing input value display and set value display

Every press of the CONF key turns on and off the CONF key alternately. With the CONF key off, the input values are displayed on the A and V/W display units.

Input value display: When the CONF key is pressed and the lamp goes out, the input values are displayed on the A and V/W display units. The discharge mode LED of the channel of the DISPLAY SELECT key lit in orange goes on.

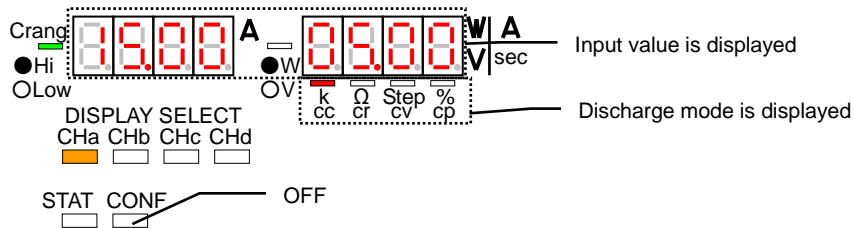

Set value display: When the CONF key is pressed and the lamp goes on, the set value and discharge mode are displayed on the A and V/W display units.

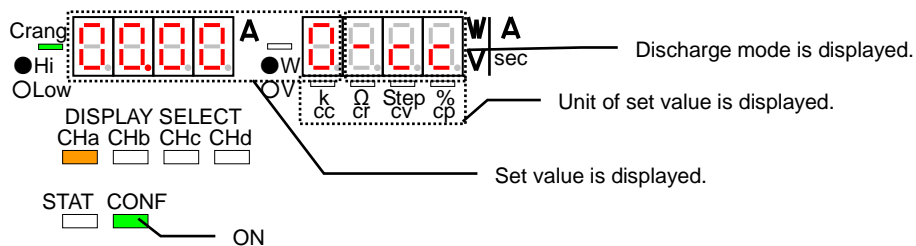

6-2-9 Display of two input current values

NOTE: The LW301-151S does not have this function.

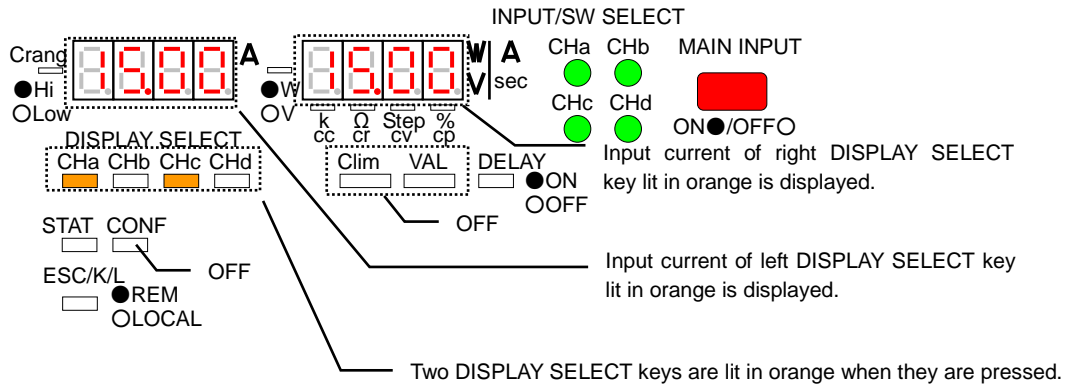

- When two DISPLAY SELECT keys are pressed and they are lit in orange in the condition where the CONF, VAL and C-lim keys are off, the input value of the channel of the left DISPLAY SELECT key lit in orange is displayed on the A display unit and the input value of the channel of the right DISPLAY SELECT key lit in orange is displayed on the V/W display unit.

NOTE: The INPUT SELECT, MAIN INPUT and PRESET keys are only functional in this condition.

- To release this condition, press one DISPLAY SELECT key or the ESC/KEY LOCK key. When a DISPLAY SELECT key is pressed, only the pressed DISPLAY SELECT key is lit in orange. When the ESC/KEY LOCK key is pressed, only the left DISPLAY SELECT key lit in orange is lit in orange.

6-2-10 Increasing and decreasing set values of CC, CV and CP modes

Select an intended digit of the set value (a maximum of five digits from the highest digit) of a discharge mode with the DIGIT key and increase or decrease it with the rotary encoder. The digit to be increased or decreased is indicated by a blinking digit of the A or V/W display unit in the condition where the VAL key is lit.

1. Every press of the VAL key turns on and off the VAL key alternately. The set value of each discharge mode may be increased or decreased when the VAL key is lit. Press the VAL key to turn it on.

NOTE: 1) In the CV mode, the VAL key may be turned on only when the CONF key is off (i.e., input value display condition) and the input voltage is displayed on the V/W display unit.

- 2) In the CP mode, the VAL key may be turned on only when the CONF key is off (i.e., input value display condition) and the input power is displayed on the V/W display unit.

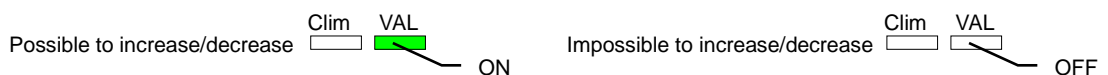

2. When the VAL key is lit, the digits of the A and V/W display units blink. However, when the lowest digit of the set value is to be increased or decreased in the condition where the CONF key is off, that digit does not blink. The blinking digits in each display condition are as shown below.

CC mode

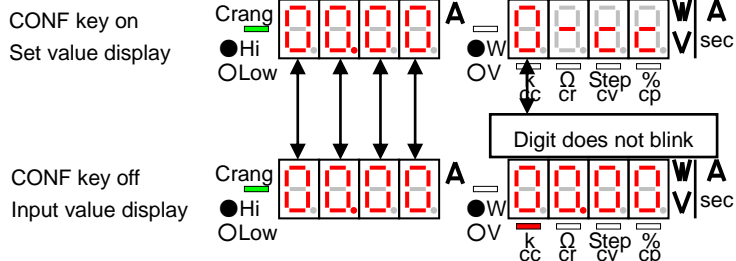

CV mode

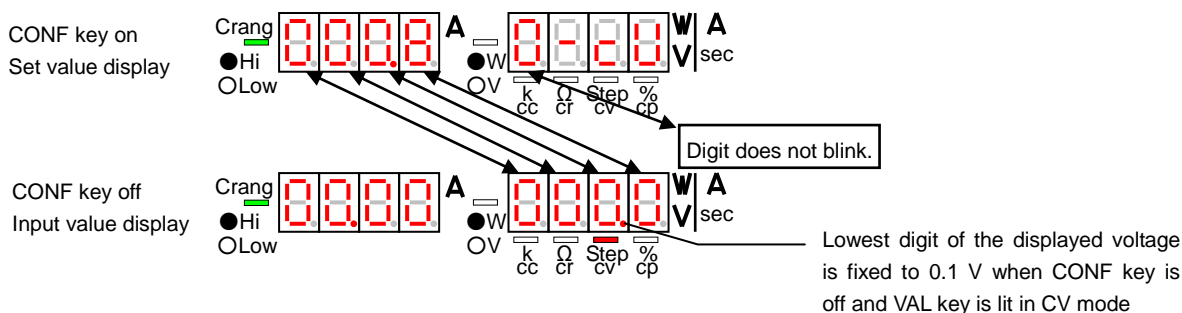

CP mode

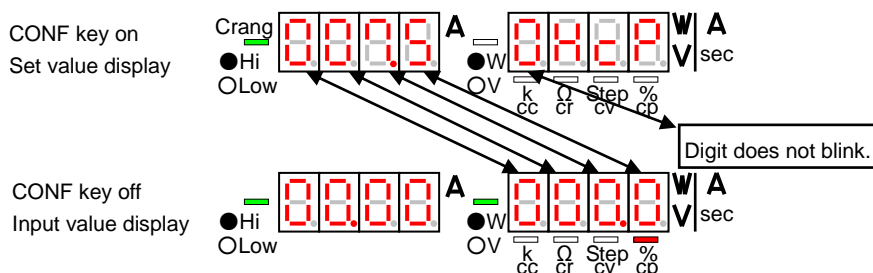

3. When the DIGIT key is operated in the condition in step 2, the blinking digit of the A or V/W display unit moves to the right or left. Pressing the left DIGIT key moves the blinking digit to the left. Pressing the right DIGIT key moves the blinking digit to the right. If the leftmost digit is blinking, it does not change even if the left DIGIT key is pressed. If the rightmost digit is blinking, it does not change even if the right DIGIT key is pressed.

4. Increase or decrease the value of the blinking digit with the rotary encoder. Rotating the rotary encoder clockwise increases the value of the blinking digit. Rotating the rotary encoder counterclockwise decreases the value of the blinking digit.

NOTE: The increased or decreased set value of the discharge mode is changed and the discharge mode operation is carried out according to the increased or decreased set value. However, unless the set value is saved in the EEPROM, it is lost when power is turned off.

6-2-11 Increasing and decreasing set values of CR mode

Select an intended digit of the STEP value (five digits from the highest digit in all) of the CR mode with the DIGIT key and increase or decrease it with the rotary encoder. The digit to be increased or decreased is indicated by a blinking digit of the A or V/W display unit in the condition where the VAL key is lit.

- Every press of the VAL key turns on and off the VAL key alternately in the condition where the CONF key is off (input value display condition). Every press of the VAL key turns on and off the VAL key alternately in the condition where the CONF key is lit (set value display condition). The set value of each discharge mode may be increased or decreased when the VAL key is lit. Press the VAL key to turn it on. The following shows the indication and display of the VAL key and A and V/W display units when the VAL key is pressed in the condition where the CONF key is lit.

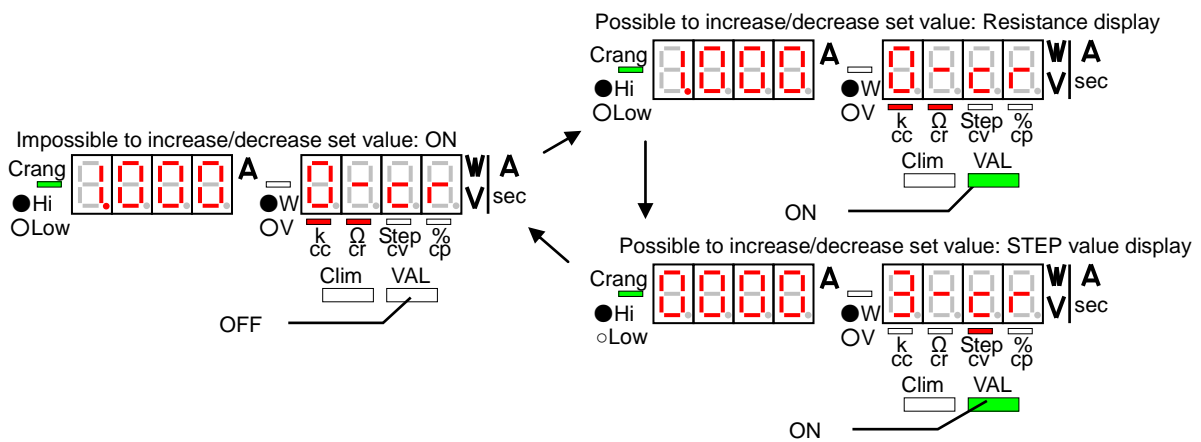

- When the VAL key is lit, the digits of the A and V/W display units blink. However, when the lowest digit of the set value is to be increased or decreased in the condition where the CONF key is off, that digit does not blink. The blinking digits in each display condition are as shown below.

CR mode

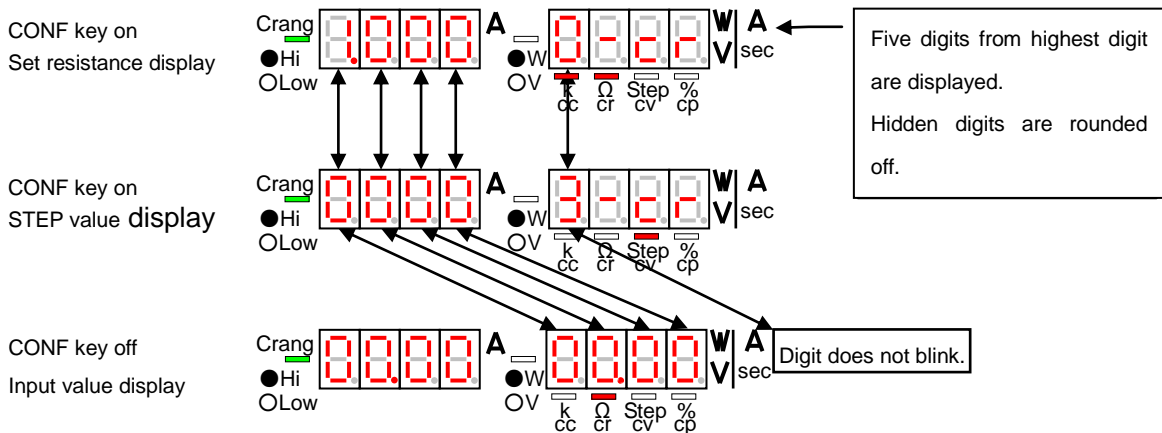

3. When the DIGIT key is operated in the condition in step 2, the blinking digit of the A or V/W display unit moves to the right or left. Pressing the left DIGIT key moves the blinking digit to the left. Pressing the right DIGIT key moves the blinking digit to the right.

STEP value display and input value display

If the leftmost digit is blinking, it does not change even if the left DIGIT key is pressed. If the rightmost digit is blinking, it does not change even if the right DIGIT key is pressed.

Resistance display

If the leftmost digit is blinking and the higher digit of the blinking digit may be set, all digits move to the right by one and the pre-settable digit blinks at the fifth digit when the left DIGIT key is pressed

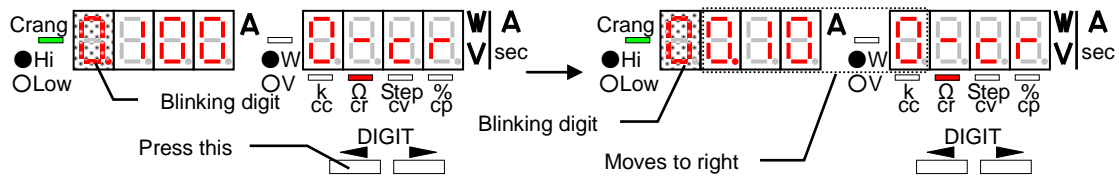

If the rightmost digit is blinking and the highest digit of the current set value is lower than the fourth digit, all digits move to the left by one and the digit lower than the displayed fourth digit blinks at the first digit when the left DIGIT key is pressed.

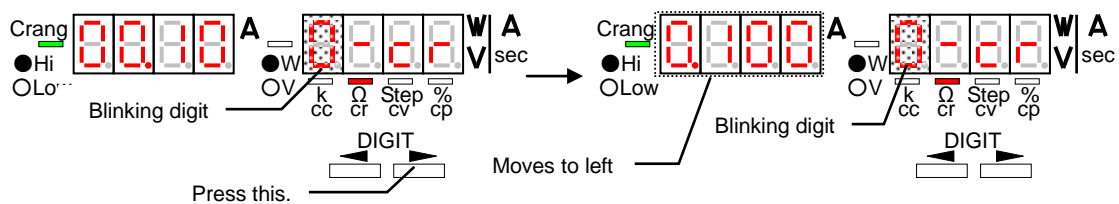

4. Increase or decrease the value of the blinking digit with the rotary encoder. Rotating the rotary encoder clockwise increases the value of the blinking digit. Rotating the rotary encoder counterclockwise decreases the value of the blinking digit.

NOTE: 1) The resistances of this unit are based on the Siemens setting. Thus, some resistances may not be set even if they are increased or decreased. See the relationship between the set resistances and STEP values.

Set resistance = $1/(S * STEP \text{ value})$: See below for the S values. STEP values are between 3 and 30000.

LW75-151Q LW75-151D	H current range: $S = 1/(3 \text{ k } \Omega) = 333 \mu\text{S}$, L current range: $S = 1/(18 \text{ k } \Omega) = 55.5 \mu\text{S}$
LW151-151D	H current range: $S = 1/(1.5 \text{ k } \Omega) = 666 \mu\text{S}$, L current range: $S = 1/(9 \text{ k } \Omega) = 111 \mu\text{S}$
LW301-151S	H current range: $S = 1/(750 \Omega) = 1.33 \text{ mS}$, L current range: $S = 1/(4.5 \text{ k } \Omega) = 222 \mu\text{S}$

- 2) The CR mode set value increased or decreased here is changed and the unit runs according to that value in the CR mode. However, unless the set value is saved in the EEPROM, it is lost when power is turned off.

6-2-12 Setting CR mode value by means of voltage and current setting

It is possible to set the CR mode value by setting the voltage and current.

1. Bring the unit into the constant-resistance mode. Turn off the TRACKING ON/OFF, CONF, VAL and C-lim keys and display the applied voltage on the V/W display unit.

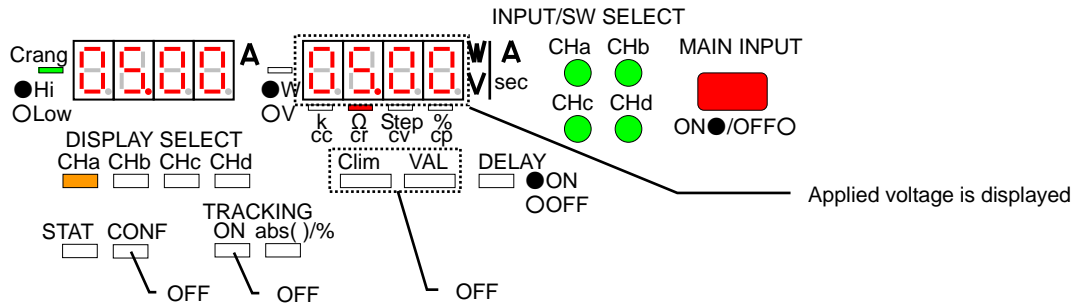

2. When the left DIGIT key is pressed in step 1, the VAL and C-lim keys blink, the value displayed on the A display unit is fixed to the value in step 1, and the value displayed on the V/W display unit is fixed to the displayed value in step 1 whose minimum digit is 0.1 V. The 0.01 V digit of the displayed voltage is rounded off.

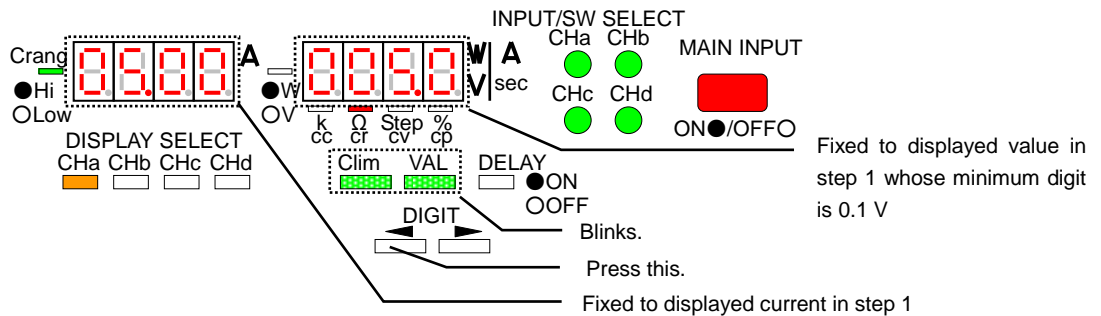

3. When the VAL key is pressed in step 2, the VAL key goes on, the C-lim key blinks, and the first digit of the V/W display unit blinks. The blinking digit of the voltage displayed on the V/W display unit may be increased or decreased with the rotary encoder. It is possible to move the blinking digit with the DIGIT key.

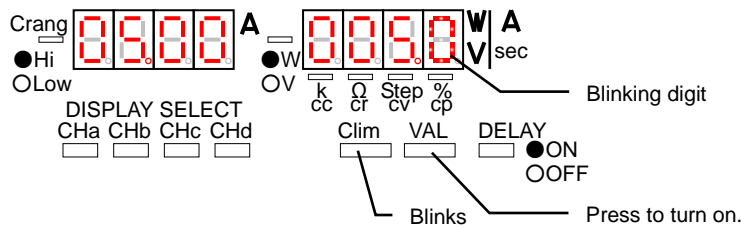

4. When the C-lim key is pressed in step 2 or 3, the C-lim key goes on, the VAL key blinks, and the first digit of the A display unit blinks. The blinking digit of the current displayed on the A display unit may be increased or decreased with the rotary encoder. It is possible to move the blinking digit with the DIGIT key.

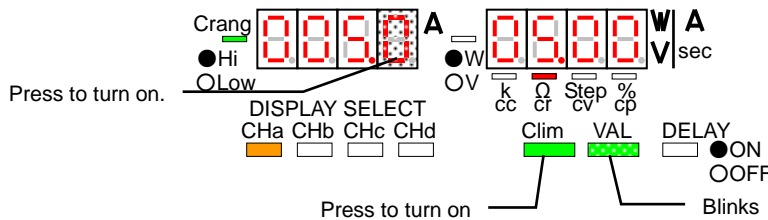

NOTE: The voltage and current displayed in steps 2 to 4 are different from the voltage and current actually input to this unit. If the ESC/KEY LOCK key is pressed in steps 2 to 4, this setting mode is canceled and the sequence returns to step 1.

- When the DISPLAY SELECT key lit in orange is pressed after increasing or decreasing the voltage displayed on the V/W display unit and current displayed on the A display unit in steps 3 and 4, the VAL key goes out, the C-lim key goes out, and the CR mode resistance is set as shown below.

Set resistance = Increased or decreased voltage/ Increased or decreased current

If the set resistance calculated above may not be set in the unit, it changes into the nearest value that may be set in the unit.

When the voltage is 0 V, the set value changes into the smallest resistance that may be set in the unit.

When the current is 0 A, the set value changes into the largest resistance that may be set in the unit.

When the voltage is 0 V and the current is 0 A, the set value changes into the smallest resistance that may be set in the unit.

NOTE: The increased or decreased CR mode set value is changed and the CR mode operation is carried out according to the increased or decreased set value. However, unless the set value is saved in the EEPROM, it is lost when power is turned off.

6-2-13 Increasing and decreasing current limit set value

The current limit mode is available in other modes than the constant-current mode. Select a digit of the set value (a maximum of four digits from the highest digit) of this mode with the DIGIT key and increase or decrease it with the rotary encoder. The digit to be increased or decreased is indicated by a blinking digit of the A display unit in the condition where the C-lim key is lit.

NOTE: It is impossible to increase or decrease the current limit set value during switching.

- Every press of the C-lim key turns on and off the C-lim key alternately. The limit current set value of this unit may be increased or decreased when the C-lim key is lit. Press the C-lim key to turn it on.

Possible to increase/decrease current limit set value

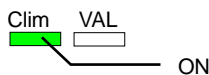

Impossible to increase/decrease current limit set value



- When the C-lim key is lit, the digits of the A and V/W display units blink. The blinking digits in each display condition are as shown below.

Current limit set value display in CR mode

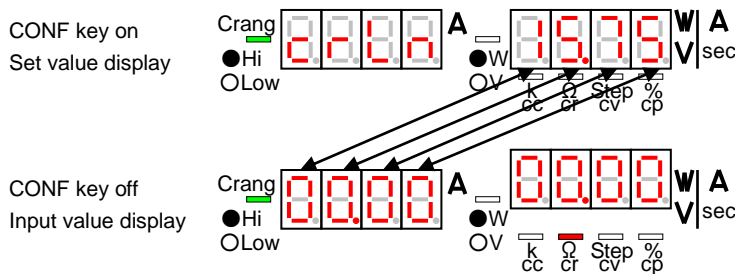

The following shows current limit mode display in the constant-voltage mode (left) and current limit mode display in the constant-power mode (right).



3. When the DIGIT key is operated in the condition in step 2, the blinking digit of the A or V/W display unit moves to the right or left. Pressing the left DIGIT key moves the blinking digit to the left, and pressing the right DIGIT key moves the blinking digit to the left. If the leftmost digit is blinking, it does not change even if the left DIGIT key is pressed. If the rightmost digit is blinking, it does not change even if the right DIGIT key is pressed.
4. Increase or decrease the value of the blinking digit with the rotary encoder. Rotating the rotary encoder clockwise increases the value of the blinking digit. Rotating the rotary encoder counterclockwise decreases the value of the blinking digit.

NOTE: The increased or decreased current limit set value is changed and operation is carried out according to the increased or decreased current limit set value. However, unless the set value is saved in the EEPROM, it is lost when power is turned off.

6-3 Memory Functions

- It is possible to set the discharge mode and set value of each channel to a PRESET key. It is also possible to recall the set data (discharge mode and set value of a channel) by selecting the PRESET key and change them.
- When the preset data and setting of the keys (INPUT/SW SELECT, DISPLAY SELECT, PRESET, TRACKING ON/OFF, and TRACKING ABS (/)/% keys) are saved in the built-in EEPROM, the preset keys have the same data and setting every time power is turned on.
- It takes approximately three seconds to save the preset data and key setting in the built-in EEPROM. During this period, key operation, rotary encoder operation and external contact control operation are all disabled.

6-3-1 Storing preset values (discharge mode and set value) in EEPROM

1. Set the intended discharge mode and set value of each channel.
2. Press the MEMORY key. All selected PRESET keys blink in green. To cancel this operation, press the MEMORY key again or press the ESC/KEY LOCK key.

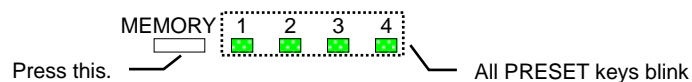

3. When a PRESET key is pressed, all DISPLAY SELECT keys and PRESET key blink. The data set in step 1 are saved in the built-in EEPROM as the preset data of the pressed PRESET key. Hereinafter, only the pressed PRESET key is lit.

6-3-2 Storing key settings in EEPROM

1. Prepare the conditions to be reproduced when power is turned on with the keys.
2. Press the MEMORY key in the condition where the MAIN INPUT key is off. All selected PRESET keys blink in green. To cancel this operation, press the MEMORY key again or press the ESC/KEY LOCK key.
3. When the DISPLAY SELECT key lit in orange is pressed, all DISPLAY SELECT keys and PRESET key blink. The data set in step 1 are saved in the built-in EEPROM as the preset data of the pressed PRESET key. Hereinafter, only the pressed PRESET key is lit.

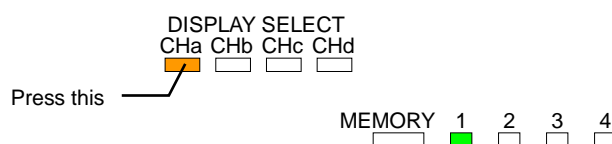

6-3-3 Recalling preset data with PRESET keys

1. Set the discharge modes and set values with two or more PRESET keys, and press those PRESET keys to turn on the keys in green. Turn off the CONF key in the condition where the MAIN INPUT key is lit (input values are displayed on the A and V/W display units).

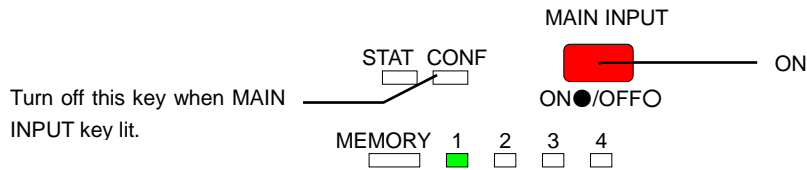

2. Press the PRESET key to which other discharge mode and set value are set to turn on the key in green. The discharge mode and set value of that PRESET key are used in each channel of the unit.

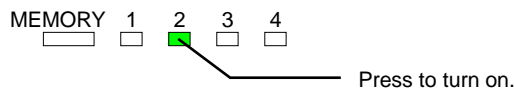

- NOTE: 1) When the MAIN INPUT and CONF keys are lit, the unit enters the condition of "Checking preset data and increasing/decreasing set value when MAIN INPUT key is lit" shown below and this operation is disabled.
- 2) Inputs of the channels whose discharge mode, current range and voltage range are set differently to the PRESET keys that are lit in steps 1 and 2 are turned off temporarily. The MAIN INPUT key remains lit.

6-3-4 Checking preset data and increasing/decreasing set value when MAIN INPUT key is lit

1. Turn on the CONF key when the MAIN INPUT key is lit. The preset discharge mode and set values are displayed on the A and V/W display units.

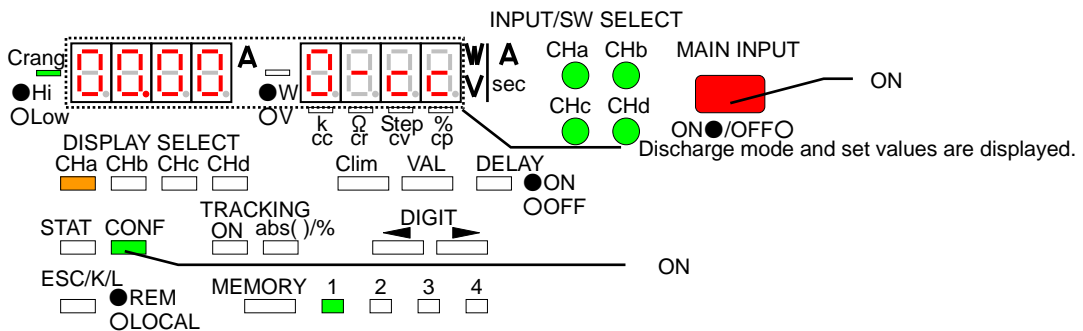

2. Press the PRESET key whose preset data should be checked. The PRESET key which is lit in step 1 remains lit, and the pressed PRESET key blinks. The discharge mode and set values of the blinking PRESET key are displayed on the A and V/W display units. Discharge mode and set values of the blinking PRESET key are displayed.

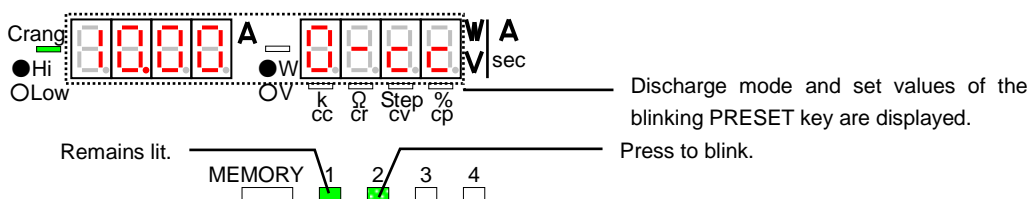

- When the VAL key is pressed in step 2, it is lit. The first digits of the set values displayed on the A and V/W display units blink. In this condition, it is possible to move the blinking digits with the DIGIT key and increase or decrease the set value with the rotary encoder.

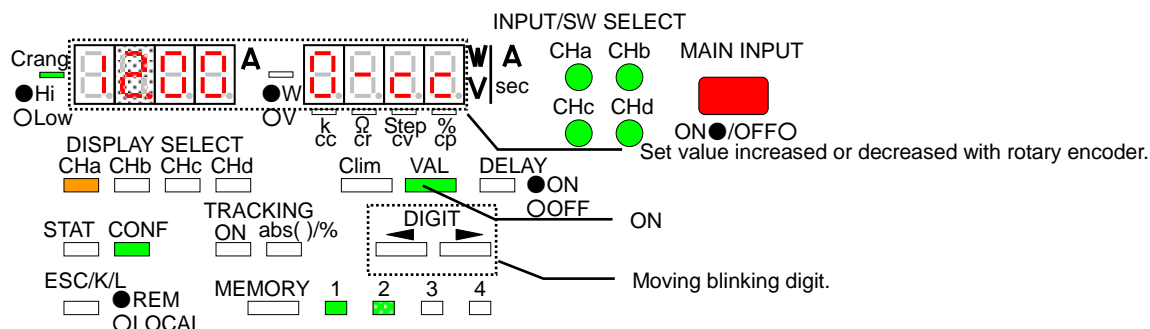

- When the DISPLAY SELECT key that is off is pressed in step 2 or 3, only the pressed DISPLAY SELECT key is lit and the discharge mode and set value of the channel of the lit DISPLAY SELECT key are displayed on the A and V/W display units. The set value may be increased or decreased in the same manner as shown in step 3.
- When the C-lim key is pressed in step 2 or 3, it is lit and the current limit value is displayed on the A and V/W display units. Their first digits blink. (This does not apply to the CC mode.) The set value may be increased or decreased in the same manner as shown in step 3.
- When a blinking PRESET key in step 3, 4 or 5, all DISPLAY SELECT key blink (for approximately three seconds). During this period, the set value increased or decreased in steps 2 to 5 is saved in the built-in EEPROM as the data of the pressed PRESET key.
- Press the ESC/KEY LOCK key to finish this operation and return to step 1.

NOTE: 1) The discharge mode or current range may not be changed in this operation.
 2) Unless the increased or decreased set value is saved in the EEPROM, it is lost when power is turned off.

6-3-5 Initializing set value

- When the power switch is thrown while pressing the MEMORY key, "EEP" is displayed on the A display unit, "cLr" is displayed on the V/W display unit, and the built-in EEPROM is initialized.
- It takes approximately 30 seconds to initialize the built-in EEPROM with the above characters displayed on the LEDs.

NOTE: 1) Do not shut off the power switch in initialization conducted for approximately 30 seconds. The initialized data are not guaranteed if the power switch is shut off during initialization. If the power switch is shut off by mistake during initialization, retry initialization.

2) This operation initializes the preset data of PRESET keys 1 to 4, settings of all keys, delay time, tracking conditions and operation method selecting function completely (to the default conditions).

6-4 Input Functions

This is a multi-input type electronic loading unit, which is capable of turn on or off the input of each channel independently. The input of each channel is turned on or off with the INPUT/SW SELECT keys. The inputs of all channels are turned on or off with the MAIN INPUT key. To turn on the inputs of this unit, make both the INPUT/SW SELECT and MAIN INPUT keys lit.

NOTE: 1) The LW301-151S has no INPUT/SW SELECT keys. The inputs are turned on and off with the MAIN INPUT key.

2) Each INPUT/SW SELECT key has a two-color LED (green and red). The INPUT/SW SELECT key whose input is turned on is lit in green. The INPUT/SW SELECT key whose switching is turned on is lit in red. The INPUT/SW SELECT key whose input and switching are turned on is lit in orange.

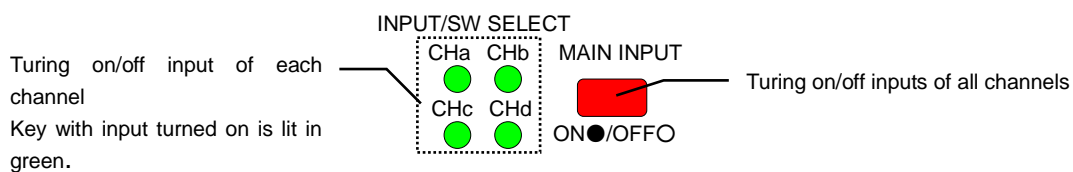

6-4-1 Turning on input

1. Every time the INPUT/SW SELECT key is pressed, it is lit in green and goes out alternately. Every time the MAIN INPUT key is pressed, it is lit in red and goes out alternately. Turn on the MAIN INPUT key.
2. Press the INPUT/SW SELECT key whose input should be turned on. The key is lit in green.
3. Turn on the MAIN INPUT key in red. The input of the channel whose INPUT/SW SELECT key is lit in green in step 2 is turned on. The inputs of the channels whose INPUT/SW SELECT keys are off are not turned on.
4. Press the INPUT/SW SELECT key that is off in the condition where the MAIN INPUT key is lit. The key is lit in green and the input of the channel of the key is turned on.

NOTE: Every time the INPUT/SW SELECT key whose switching is turned on is pressed, it is lit in red and lit in orange alternately.

6-4-2 Turning off input

1. Make all INPUT/SW SELECT keys lit in green and MAIN INPUT key lit in red. Inputs of all channels are turned on.
2. Turn off the INPUT/SW SELECT key of the channel whose input should be turned off. The input of the channel of the turned off INPUT/SW SELECT key is turned off.
3. Turn off the MAIN INPUT key. The inputs of all channels are turned off.

6-5 Switching Functions

- This is a multi-input type electronic loading unit capable of turning on or off switching of each channel. Turn on or off switching of each channel with the INPUT/SW SELECT keys.
- This unit switches the set values of the discharge modes set to PRESET 1 and 2 (PRESET key 1 or 2 is selected) or PRESET 3 and 4 (PRESET key 3 or 4 is selected) at a certain interval. For the method of setting the switching time, see "Operation of switching time setting method 1" and "Operation of switching time setting method 2".
- It is possible to set different discharge modes to the channels. However, if different discharge modes and set values are set to PRESET 1 and 2 and PRESET 3 and 4 in a channel, it is impossible to turn on switching of that channel.
- The greater one of the set values set to PRESET 1 and 2 and PRESET 3 and 4 serves as the current limit value during switching. It is impossible to increase or decrease the current limit value during switching.

NOTE: 1) The LW301-151S has no INPUT/SW SELECT keys. Switching is turned on and off with the SW key.

- 2) Each INPUT/SW SELECT key has a two-color LED (green and red). The INPUT/SW SELECT key whose input is turned on is lit in green. The INPUT/SW SELECT key whose switching is turned on is lit in red. The INPUT/SW SELECT key whose input and switching are turned on is lit in orange.

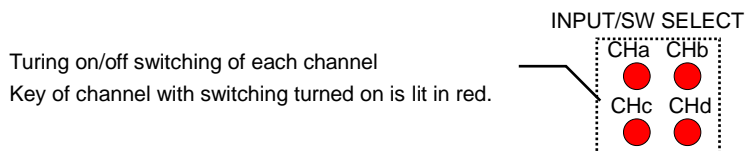

6-5-1 Turning on/off switching

1. Turn off the VAL and C-lim keys. Every time the INPUT/SW SELECT key is pressed while holding the right DIGIT/SW key in this condition, that INPUT/SW SELECT key is lit in red and goes out alternately.
2. Press the INPUT/SW SELECT key of the channel whose switching should be turned on. The key is lit in red. Switching of the channel of the key lit in red is turned on.
3. Turn off the INPUT/SW SELECT key of the channel whose switching should be turned off. The key goes out and switching is turned off.

NOTE: 1) Every time the INPUT/SW SELECT key whose input is turned on is pressed while holding the right DIGIT key, it is lit in green and lit in orange alternately.

- 2) Switching of the LW301-151S may be turned on and off with the SW key only.

6-6 Delay Functions

- It is possible to delay the point of turning on (or off) the input of each channel by 0.1 to 10.0 seconds from the moment when operating the MAIN INPUT key.
- During the delay function is working (MAIN INPUT key is blinking), no operations are enabled, except for the MAIN INPUT key. (Turning off the blinking MAIN INPUT key)
- For the setting of the delay time, see "Setting delay time".
- The LW301-151S has no delay function.

6-6-1 Turning on input using delay function

1. Set the delay time of each channel when the MAIN INPUT key is off.
For the setting of the delay time, see "Setting delay time".
 2. Press the INPUT SELECT key of the channel whose input should be turned on.
The key goes on.
 3. Every time the DELAY key is pressed, it goes on and out alternately.
Press the DELAY key to turn it on.
 4. When the MAIN INPUT key is pressed while it is off, it blinks and the unit enters the delay mode.
On completion of the delay operation, the MAIN INPUT key is lit.
- NOTE: When the MAIN INPUT key is pressed while it is blinking in red, it goes out and the inputs of all channels are turned off.

6-6-2 Turning off input using delay function

1. Set the delay time of each channel when the MAIN INPUT key is off.
 2. Press the DELAY key while the MAIN INPUT key is lit to turn on the DELAY key.
 3. When the MAIN INPUT key is pressed while it is lit, it blinks and the unit enters the delay mode. On completion of the delay operation, the MAIN INPUT key goes out.
- NOTE: When the MAIN INPUT key is pressed while it is blinking in red, it goes out and the inputs of all channels are turned off.

6-7 Tracking Functions

- The tracking function increases or decreases the set values of several channels simultaneously. Two tracking modes are available: "Absolute value tracking mode" that increases or decreases the set values of the channels by the same value, and "% tracking mode" that increases or decreases the set values by percentage, assuming the value when tracking is turned on as 100%. It is also possible to select "+ tracking" that changes the values in the positive direction when rotating the rotary encoder clockwise and "- tracking" that changes the values in the negative direction.
- In the absolute tracking mode, the tracking function may not be turned on unless the discharge mode and current range are identical.
- In the % tracking mode, the tracking function may not be turned on unless the discharge mode is identical.
- If tracking operation is executed in the CR mode, the set resistance is increased or decreased step by step.
- Tracking operation does not apply to the current limit value, though only the set value of each discharge mode may be changed.
- For setting the tracking function, see "Setting tracking".
- The LW301-151S does not have the tracking function.

6-7-1 Turning on/off tracking operation

1. Turn off the MAIN INPUT and TRACKING ON/OFF keys, and set the tracking function of each channel.
2. Every time the TRACKING abs ()/% key is pressed, it goes on and out alternately. The TRACKING abs ()/% key should be off or on. When the key is lit, the absolute value tracking mode is selected. When it is off, the % tracking mode is selected.

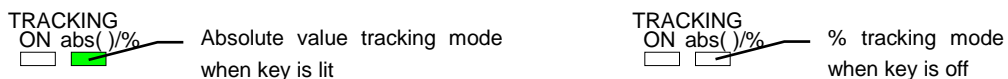

3. Every time the TRACKING ON/OFF key is pressed in the condition where the VAL key is lit, the TRACKING ON/OFF key goes on and out alternately. (It is impossible to turn on the TRACKING ON/OFF key unless the VAL key is lit.) Turn on the TRACKING ON/OFF key. If the % tracking mode is selected at this time, the set value of each discharge mode at the point when the TRACKING ON/OFF key goes on serves as 100%. While the TRACKING ON/OFF key is lit, the DISPLAY/STATUS key is lit in green or orange in the set tracking condition (lit in green: + tracking, lit in red: - tracking, Off: no tracking operation). (The DISPLAY/STATUS key of the channel displayed on the A and V/W display units is lit in orange.)

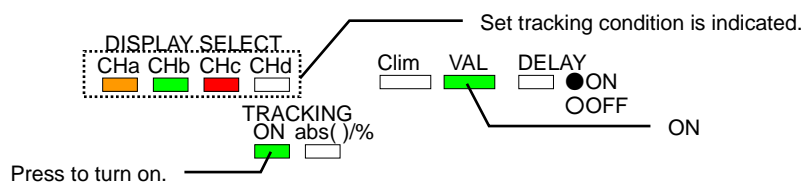

4. When the TRACKING ON/OFF key is pressed in the condition where it is lit, it goes out and tracking is deactivated.

- NOTE: 1) If tracking is not set in any channels, it is impossible to turn on the TRACKING ON/OFF key.
- 2) It is impossible to activate tracking while the DISPLAY SELECT key of the channel in which tracking is not set is lit in orange.
 - 3) When the DISPLAY SELECT key of the channel in which tracking is not set is lit in orange, the DISPLAY SELECT key of all channels in which tracking is set go out.
 - 4) When the ESC/KEY LOCK key is pressed in this operation, the TRACKING ON/OFF and VAL keys go out and tracking is deactivated.
 - 5) There is no time-out, even if the time-out time is set, during tracking operation (TRACKING ON/OFF key is lit).
 - 6) The PRESET keys are not functional during tracking.
 - 7) The VAL key not functional during tracking.

6-7-2 Increasing or decreasing set value in absolute value tracking mode

1. Turn on the DISPLAY SELECT key of the channel in which tracking is set, TRACKING abs ()/% key, VAL key and TRACKING ON/OFF key.
2. Select a digit to be increased or decreased with the DIGIT key, and increase or decrease the value with the rotary encoder. Rotating the rotary encoder clockwise increases the set values of + tracking channels and decreases the set values of - tracking channels. Rotating the rotary encoder counterclockwise decreases the set values of + tracking channels and increases the set values of - tracking channels.
3. When the CONF key is operated, either the set value (CONF key lit) or input value (CONF key off) is displayed on the A and V/W display units. In set value display or input value display, the value of the same digit as increasing or decreasing the set value in the normal discharge mode is increased or decreased.

- NOTE: 1) If the DISPLAY SELECT key to which tracking is not set is lit in orange and the set value is increased or decreased, the set values of the channels in which tracking is set are not increased or decreased.
- 2) In the CR mode, the STEP values are increased or decreased. The set resistance may not be increased or decreased.

6-7-3 Checking CR mode set resistance in absolute value tracking mode

1. Bring the unit into the absolute value tracking mode. Turn on the CONF key. The set STEP values are displayed on the A and V/W display units.
2. Press the DISPLAY SELECT key lit in orange. It blinks in orange, and the set resistance is displayed on the A and V/W display units. It is impossible to increase or decrease the set resistance in this condition. Press the DISPLAY SELECT key blinking in orange. It is lit in orange, and the set STEP value is displayed on the A and V/W display units.

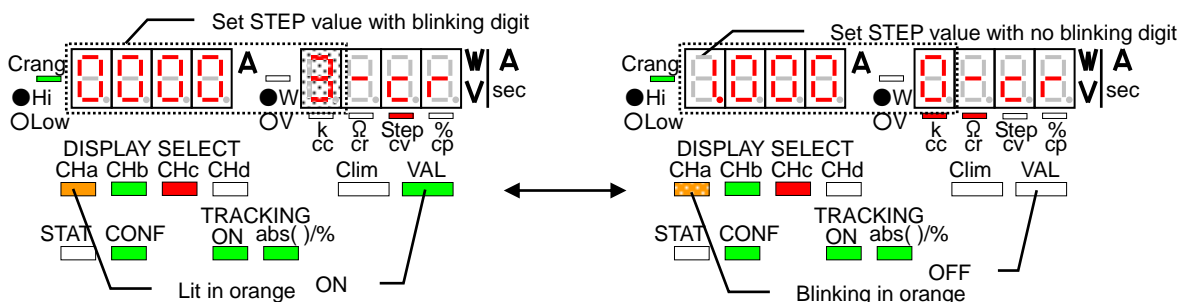

6-7-4 Increasing or decreasing set value in % tracking mode

1. Turn on the DISPLAY SELECT key of the channel in which tracking is set and TRACKING abs ()/% key. Turn off the VAL key.
2. Turn on the TRACKING ON/OFF key. In the % tracking mode, the set value of each channel is regarded as 100% when this key goes on.
3. Select a digit to be increased or decreased with the DIGIT key, and increase or decrease the value with the rotary encoder. Rotating the rotary encoder clockwise increases the set values of + tracking channels and decreases the set values of - tracking channels. Rotating the rotary encoder counterclockwise decreases the set values of + tracking channels and increases the set values of - tracking channels.
4. When the CONF key is operated, either the set % (CONF key lit) or input value (CONF key off) is displayed on the A and V/W display units. The following shows the relationship between increasing or decreasing the set value in set % display or input value display and increasing or decreasing the set value in the normal discharge mode.

CR mode

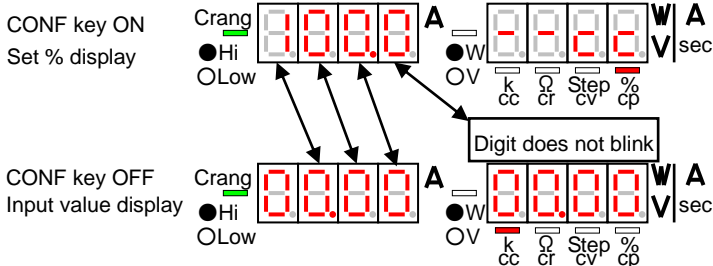

CR mode

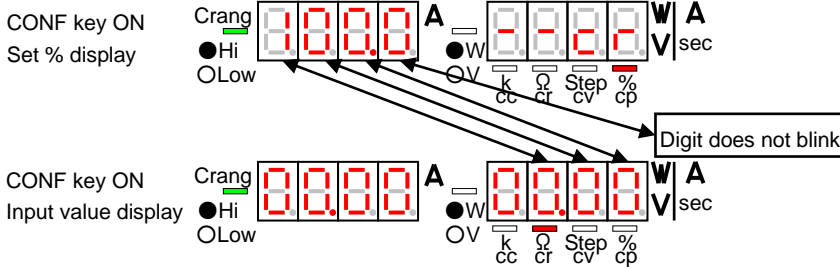

CV mode

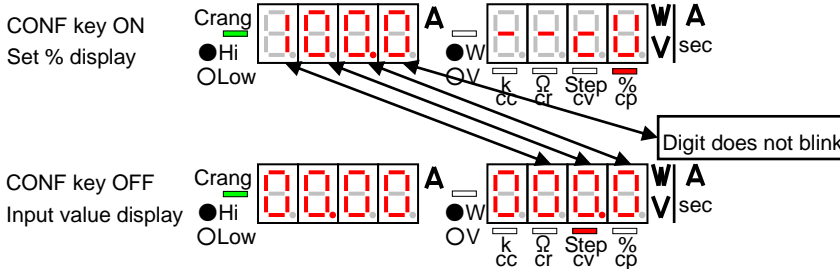

CP mode

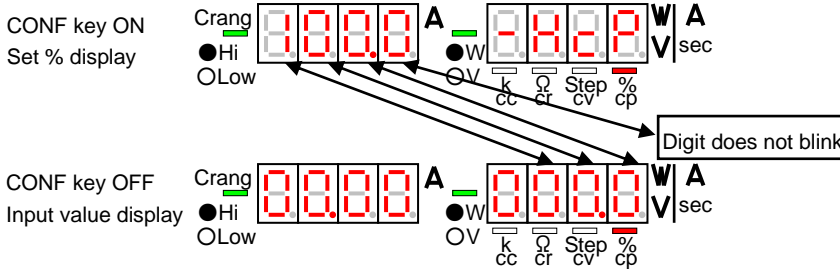

NOTE: If the DISPLAY SELECT key to which tracking is not set is lit in orange and the set value is increased or decreased, the set values of the channels in which tracking is set are not increased or decreased.

6-7-5 Checking set value in % tracking mode

1. Bring the unit into the absolute value tracking mode. Turn on the CONF key. The set % values are displayed on the A and V/W display units.
2. Press the DISPLAY SELECT key lit in orange. It blinks in orange, and the set values are displayed on the A and V/W display units. It is impossible to increase or decrease the set resistance in this condition.

3. Discharge mode other than CR mode

Press the blinking DISPLAY SELECT key. It is lit in orange, and the set % is displayed on the A and V/W display units.

CR mode

Press the DISPLAY SELECT key blinking in orange. It keeps blinking in orange, and the set resistance is displayed on the A and V/W display units. When the key is pressed again, it is lit in orange, and the set % is displayed on the A and V/W display units.

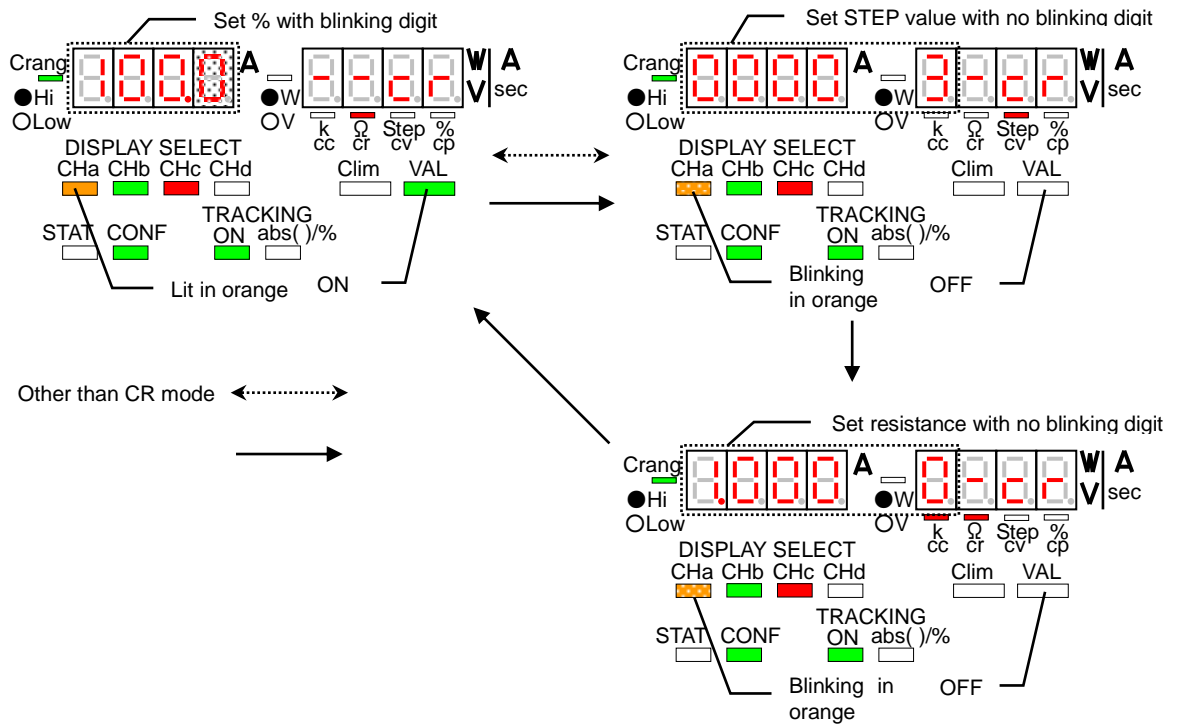

6-7-6 Example of increasing/decreasing set values with tracking mode active

The table below shows an example of increasing or decreasing the set values of the LW75-151Q when the tracking mode is activated.

	Set current with tracking mode active	Tracking setting
Channel A	5.00 A	+
Channel B	10.00 A	+
Channel C	5.00 A	-
Channel D	2.00 A	+

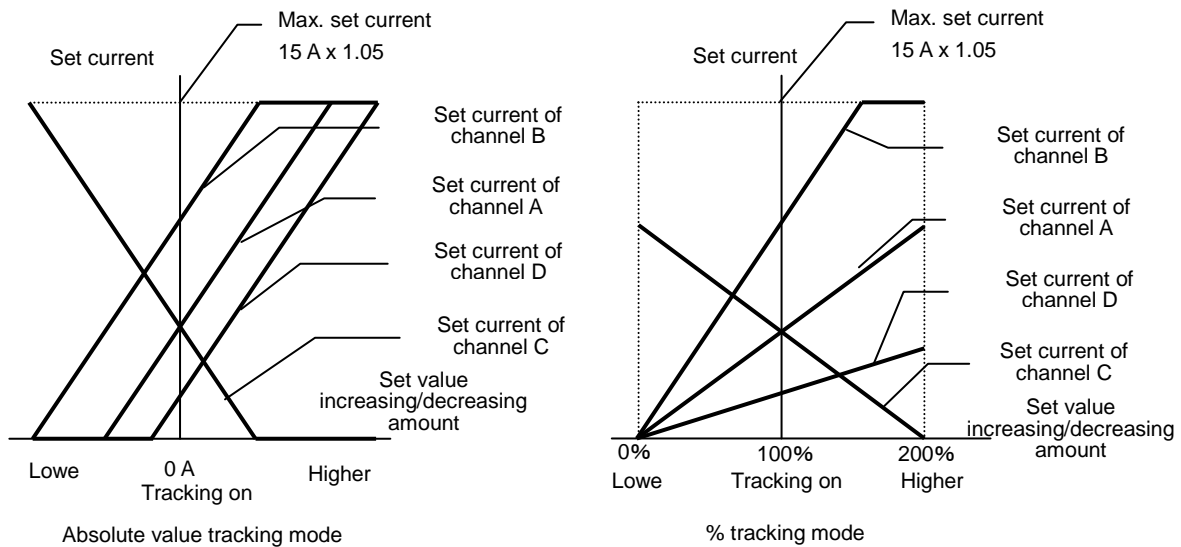

6-8 Releasing Alarms

6-8-1 Occurrence of EAR (external alarm) and releasing it

1. If this alarm occurs, the MAIN INPUT key goes out and the inputs of all channels are turned off forcibly.
2. When the unit is in the EAR status, "ALП" and "EtA" are displayed on the A and V/W display units, respectively. In addition, all INPUT/SW SELECT keys blink in red. In this condition, operations are disabled on the unit.
3. If pins 1 and 2 of the external contact control connector (J1) on the rear panel are opened after the OHA alarm occurs, "ALП" disappears from the A display unit, though "EtA" remains on the V/W display unit and all INPUT/SW SELECT keys continue blinking in red. Operations are still disabled on the unit.
4. To cancel the above-mentioned status, hold the DISPLAY SELECT key lit in orange.

NOTE: It is impossible to release the unit from the EAR status even if the operation shown in step 4 is carried out in the condition where "ALП" is displayed on the A display unit.

6-8-2 Occurrence of OHA (overheat alarm) and releasing it

1. If this alarm occurs, the MAIN INPUT key goes out and the inputs of all channels are turned off forcibly.
2. When the unit is in the OHA status, "AL Π" and "oHA" are displayed on the A and V/W display units, respectively. In addition, all INPUT/SW SELECT keys blink in red. In this condition, operations are disabled on the unit.
3. If the internal temperature lowers after the OHA alarm occurs, "AL Π" disappears from the A display unit, though "oHA" remains on the V/W display unit and all INPUT/SW SELECT keys continue blinking in red. Operations are still disabled on the unit.
4. To cancel the above-mentioned status, hold the DISPLAY SELECT key lit in orange.

NOTE: It is impossible to release the unit from the OHA status even if the operation shown in step 4 is carried out in the condition where "AL Π" is displayed on the A display unit.

6-8-3 Occurrence of OVA (over-voltage application alarm) and releasing it

1. If this alarm occurs, the INPUT/SW SELECT key of the channel where the alarm occurs blinks in red, and the input of that channel only is turned off. In this condition, the DISPLAY SELECT and MAIN INPUT keys may only be turned off. Any other operations are disabled.
2. When the DISPLAY SELECT key of the channel where the OVA alarm occurs is pressed and it is lit in orange in step 1, "AL Π" and "oVA" are displayed on the A and V/W display units, respectively.
3. If the over-voltage applied to the unit is cut off, "AL Π" disappears from the A display unit, though "oVA" remains on the V/W display unit and the INPUT/SW SELECT key of the channels where the OVA alarm occurs continues blinking in red. In addition, any operations, except turning off the DISPLAY SELECT and MAIN INPUT keys, are still disabled.
4. To cancel the above-mentioned status, hold the DISPLAY SELECT key of the channel where the OVA alarm occurs.

NOTE: It is impossible to release the unit from the OVA status even if the operation shown in step 4 is carried out in the condition where "AL Π" is displayed on the A display unit.

6-8-4 Occurrence of OCA (over-current input alarm) and releasing it

1. If this alarm occurs, the INPUT/SW SELECT key of the channel where the alarm occurs blinks in red, and the input of that channel only are turned off. In this condition, the DISPLAY SELECT and MAIN INPUT keys may only be turned off. Any other operations are disabled.
2. When the DISPLAY SELECT key of the channel where the OCA alarm occurs is pressed and it is lit in orange in step 1, "AL Π" and "oCA" are displayed on the A and V/W display units, respectively.
3. If the over-current applied to the unit is cut off, "AL Π" disappears from the A display unit, though "oCA" remains on the V/W display unit and the INPUT/SW SELECT key of the channels where the OCA alarm occurs continues blinking in red. In addition, any operations, except turning off the DISPLAY SELECT and MAIN INPUT keys, are still disabled.
4. To cancel the above-mentioned status, hold the DISPLAY SELECT key of the channel where the OCA alarm occurs.

NOTE: It is impossible to release the unit from the OCA status even if the operation shown in step 4 is carried out in the condition where "AL Π" is displayed on the A display unit.

Stop supplying power to the unit if "AL Π" does not disappear from the A display unit when the INPUT/SW SELECT key of the channels where the OCA alarm occurs is lit in orange. In such a case, the unit may be defective.

6-9 Key Lock Function

- This function alternates the key locked status and local status of the unit.
- Key locked status (lit in green): Any keys, except for the ESC/KEY LOCK key, are not functional.
- Local status (lit in red): The unit is in the remote control mode. Any keys, except for the ESC/KEY LOCK key, are not functional.
(Operation procedures)
- If manual operation is conducted on the panel, it is possible to switch the key locked status and local status by holding the ESC/KEY LOCK key for approximately three seconds.
- When a signal is sent to the unit through the IF-50GP/USB (in the remote mode), the ESC/KEY LOCK key is lit and panel operation is disabled. If ESC/KEY LOCK key is pressed in this condition, the key goes out and operations on the panel are enabled. When a signal is sent again in the remote control mode, the key goes on and the unit enters the remote mode.
- In the external contact control status, the ESC/KEY LOCK key blinks. When it is pressed in this blinking condition, the key lock function works, though the key is still blinking. Press the key again to release the key lock status.

6-10 Usage of Voltage Remote Sensing Function

Using this function, it is possible to compensate for the voltage drop caused by the load cable connected between this unit and power supply and measure the voltage of the power supply.

1. Turn off the MAIN INPUT key of the unit. (Main input Off)
2. Set the voltage remote sensing selector switch at the optional board mount to the EXT side.
3. Connect the power supply with the input terminals of the unit with a load cable, etc.
4. Connect the + terminal of the power supply with the + voltage remote sensing connector of the unit and - terminal of the power supply with the - voltage remote sensing connector of the unit with wires, etc.

NOTE: 1) Be careful not to mistake the polarity when connecting the sensing connectors with the power supply. Do not connect the voltage remote sensing connector with any input terminals, since this unit is a multi-input electronic loading unit. Otherwise, the unit may malfunction or break down.

- 2) Too long a load cable or sensing wires may cause oscillation. In such a case, be sure to make the load cable and sensing wires into a twisted pair. Connect a capacitor between the input terminals of the unit.
- 3) Set voltage remote sensing selector switch to the IN side. Set the other switch to the F position when using the front input terminals. Set it to the R position when using the rear input terminals.

7. EXTERNAL CONTACT CONTROL

7-1 Functions

- It is possible to operate the MAIN INPUT key and PRESET keys 1 to 4 or INPUT SELECT key of the unit using, input and output of alarm signal through the external contact input and output connector (J1) on the rear panel. It is also possible to input an external alarm (for turning off the main input forcedly) and detect the alarm signal using the connector J1.
- Select whether to operate the PRESET keys or the INPUT SELECT key using the rear contact function when turning on power.
- Open all pins of J1 when operations are to be done on the front panel.
- When pin 3 of J1 is short-circuited with pins 4 to 8 of J1, the ESC/KEY LOCK key on the front panel blinks in green.
- The connector J1 is connected with the built-in digital circuit. When the unit is controlled from a computer through the IF-50GP/USB, the built-in digital circuit has the same potential as the computer. Thus, the circuit connected with the connector J1 must be in the floating condition.
- In external point-of-contact control and IF-50GP/USB control, IF-50GP/USB control is that priority is given.

7-2 Specifications of Remote Contact Control Connector

Pin No.	Function
1 & 2	Short-circuit to input or detect an alarm signal.
3	COM terminal of the built-in circuit. Short-circuit with pin 4 to 8 to enable external contact control.
4	Short-circuit with pin 3 to select PRESET 1 key or channel A INPUT SELECT key. (Except for the LW301-151S)
5	Short-circuit with pin 3 to select PRESET 2 key or channel B INPUT SELECT key. (Except for the LW301-151S)
6	Short-circuit with pin 3 to select PRESET 3 key or channel C INPUT SELECT key. (Except for the LW301-151S)
7	Short-circuit with pin 3 to select PRESET 4 key or channel D INPUT SELECT key. (Except for the LW301-151S, LW151-151D and LW75-151D)
8	Short-circuit with pin 3 to turn on the MAIN INPUT.

Voltmeter: Approx. 0 V is input when the unit is in the alarm status.

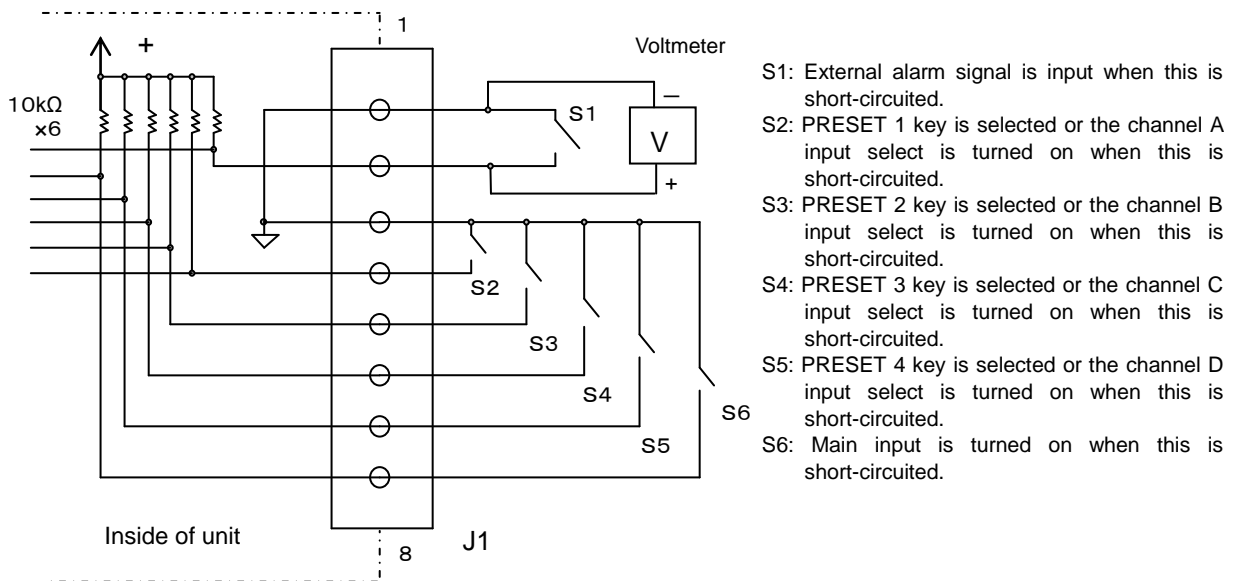

- Use the lead wires with a connector supplied with the unit for the connector J1. The lead wires with a connector are color-coded according to the marks on J1 on the rear panel.

- If it is necessary to extend the lead wires with a connector supplied with the unit, solder them properly and wind insulation tube around the connections to protect them.
- The lead wires with a connector supplied with the unit are coded in the same colors marked on J1 on the rear panel.

7-3 Usage

7-3-1 External alarm terminals

If the unit enters the alarm condition, an alarm signal is output. It is possible to turn off the main input of the unit using an external signal.

Output alarm signal

1. The voltage at pin 2 of the connector J1 on the rear panel is measured, regarding the voltage of pin 1 as the standard. Voltage of approximately +1.5 V is output when the unit is not in the alarm condition.
2. Pins 2 and 1 of J1 are short-circuited by the intermediation of a built-in transistor when the unit is in the alarm status.

Input alarm signal

1. Make the MAIN INPUT key lit to turn on the main input of the unit.
2. Short-circuit pins 1 and 2 of the connector J1 on the rear panel with contacts, etc. The MAIN INPUT key goes out and the input is turned off.

Alarm signal connection of several units

1. Connect J1 pins 2 of several units with one another. Likewise, connect pins 1 with one another.
2. Make the MAIN INPUT keys of all units lit to turn on the main input.
3. When one of these units enters the alarm condition, the other units enter the alarm conditions and their inputs are turned off.

NOTE: 1) Pin 1 of the connector J1 is designed for input and output of the alarm signal. This connector supplies no power.

2) It is possible to connect a maximum of five units for alarm signal connection.

3) The circuit connected with the connector J1 must be in the floating condition.

7-3-2 Selecting PRESET 1 to 4 keys using external contacts

1. Short-circuit J1 pin 3 and one of pins 4 to 7 of the unit.
2. PRESET 1 is selected when pin 4 is short-circuited. PRESET 2 is selected when pin 5 is short-circuited. PRESET 3 is selected when pin 6 is short-circuited. PRESET 4 is selected when pin 7 is short-circuited.

NOTE: 1) This operation is disabled if the INPUT SELECT key is selected with the rear contact function when turning on power.

2) The PRESET keys on the front panel are invalid when some PRESET is selected using the connector J1.

3) The order of priority is as shown below when several PRESET keys are selected using the connector J1:

PRESET 1 > PRESET 2 > PRESET 3 > PRESET 4

4) The circuit connected with the connector J1 must be in the floating condition.

7-3-3 Turning ON/OFF input select using external contacts

1. Open J1 pin 3 and pin 4 to 7 of the unit. All INPUT SELECT keys go out (Off).
2. Short-circuit J1 pin 3 and one of pins 4 to 7 of the unit. The INPUT SELECT key of the channel A is lit

(ON) in green when pin 4 is short-circuited. The INPUT SELECT key of the channel B is lit (ON) in green when pin 5 is short-circuited. The INPUT SELECT key of the channel C is lit (ON) in green when pin 6 is short-circuited. The INPUT SELECT key of the channel D is lit (ON) in green when pin 7 is short-circuited. The equivalent PRESET key on the front panel is also lit.

NOTE: 1) This operation is disabled if the PRESET key is selected with the rear contact function when turning on power.

2) The INPUT SELECT key may not be turned on or off on the front panel if the INPUT SELECT key is selected with the rear contact function when turning on power.

3) It is impossible to turn on the input select function of any channel with no INPUT SELECT key through the above-shown operation.

4) The circuit connected with the connector J1 must be in the floating condition.

7-3-4 Turning ON/OFF main input using external contacts

Short-circuit pins 3 and 8 to turn on the main input.

Open these pins to turn off the main input.

NOTE: 1) It is impossible to turn on the main input if the unit is in the alarm condition. The circuit connected with the connector J1 must be in the floating condition.

2) If the pin status (short circuit or open) is changed in delay operation, the unit discontinues the delay operation. The ON/OFF status of the main input after discontinuation of the delay operation becomes identical to the external contact status. (Short circuit: OFF, open: ON)

3) The circuit connected with the connector J1 must be in the floating condition.

8. EXTERNAL VOLTAGE CONTROL

- This function is only available on the models, which are provided with the external voltage control function. This function is a factory option.
- It is possible to set the value of each discharge mode of the unit by applying external voltage (0 to 10 V) to the external voltage input connector (hereinafter referred to as J2) on the rear panel.
- Select the external voltage control function as described in "Setting of Discharge Modes" to use this function.
- The input terminals of the unit is floated from the unit casing and other input terminals. J2 is connected with each negative input terminal. Thus, use external voltage to be applied to J2 in the floating condition.
- It is impossible to increase or decrease the set value of a selected external-voltage-control channel using the rotary encoder, except the CC mode. The set value in the CC mode is the sum of the set value increased or decreased on the panel and the value set by the external voltage control function.

8-1 Pins for External Voltage Control

8-1-1 Specifications of J2

Pin No.	Function			
	LW75-151Q	LW75-151D	LW151-151D	LW301-151S
1 & 3	Channel A voltage input			
2	NC			
4 & 6	Channel B voltage input		NC	
5	NC			
7 & 9	Channel C voltage input	NC	Channel B voltage input	NC
8	NC			
10 & 12	Channel D voltage input	NC		
11	NC			

NOTE: Apply voltage between 0 and +10 V to J2.

The maximum voltage to be applied must be ± 12 V or less.

8-1-2 Connecting external voltage source and J2

1. Peel off the insulating sheaths from the end of the wires connected with the external voltage source by approximately 10 mm.

Prepare a screwdriver with a 2.6-mm wide flat head. Hold the button "B" of J2 and insert the bare conductor of each wire into "A".

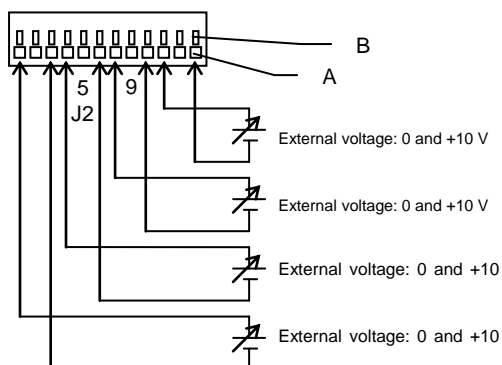

Applicable wires

Single wire: 0.32 mm dia. (AWG28) to 0.65 mm dia. (AWG22)

Stranded wire: 0.08 mm² (AWG28) to 0.32 mm² (AWG22), strand diameter 0.125 mm dia. or more

8-1-3 Specifications of controls

Control name	Function			
	LW75-151Q	LW75-151D	LW151-151D	LW301-151S
OFFSET 1	Adjusting channel A offset			
GAIN 1	Adjusting channel A gain			
OFFSET 2	Adjusting channel B offset		Unused	
GAIN 2	Adjusting channel B gain			
OFFSET 3	Adjusting channel C offset	Unused	Adjusting channel B offset	Unused
GAIN 3	Adjusting channel C gain		Adjusting channel B gain	
OFFSET 4	Adjusting channel D offset	Unused		
GAIN 4	Adjusting channel D gain			

Adjust each control with the adjusting screwdriver supplied with the product.

8-2 Usage of External Voltage Control Function

8-2-1 Checking set value of external voltage control

Turn on the CONF key, and the set value in each discharge mode is displayed on the A and V./W display units. Use the VAL key in this condition to change the set value in each discharge mode displayed on the A and V./W display units.

In the CC mode

Every time the VAL key is pressed, it turns on and off alternately. The value set by the external voltage control function is displayed on the A and V./ W display units when the VAL key is unlit. The value set on the panel is displayed on the A and V/ W display units when the VAL key is lit.

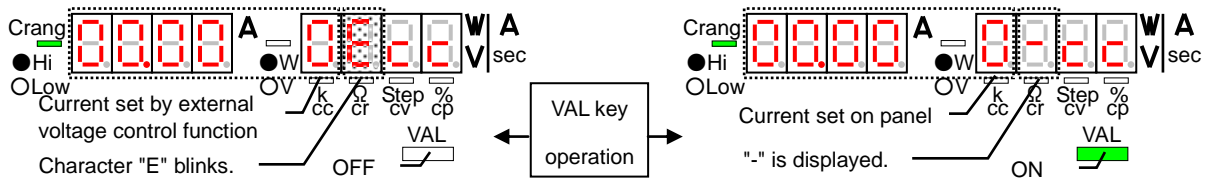

In the CR mode

Every time the VAL key is pressed, the resistance set by the external voltage control function and the step value set by the external voltage control function are displayed alternately on the A and V./W display units. The VAL key itself remains off.

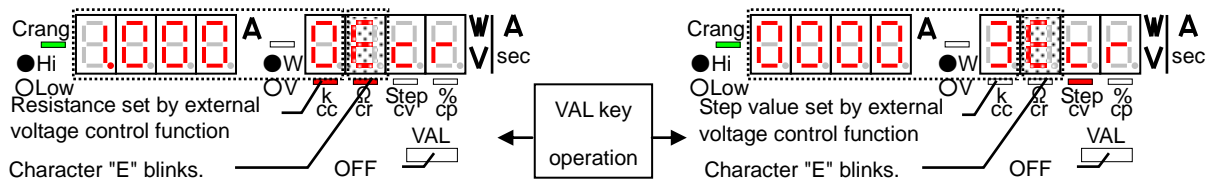

In the CV or CP mode

The VAL key remains off and the value set by the external voltage control function is displayed on the A and V/ W display units when the VAL key is pressed. In the CP mode, "E" and "L" or "H", which indicates the voltage range, is displayed alternately.

8-2-2 Adjusting set value using external voltage

1. Turn off the main input. Cause the DISPLAY SELECT key of the external-voltage-control channel to be lit in orange.
2. Turn off the VAL key and C-lim key, and turn on the CONF key. The value set by the external voltage control function is displayed on the A and V/W display units. In the CR mode, display the set step value.

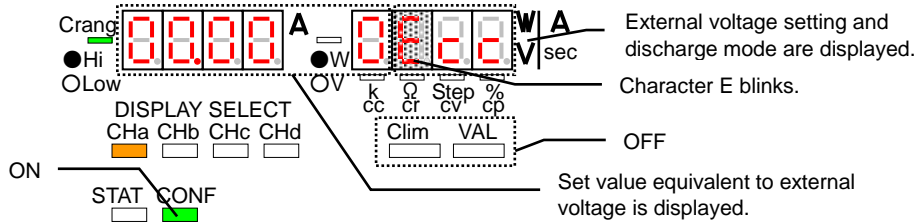

3. Apply external voltage to J2, and adjust the external voltage to 1 V. Set the value displayed on the A and V.W display units to 10% of the rated value in each discharge mode with the OFFSET control. Set it to "3000" (step value) in the CR mode.

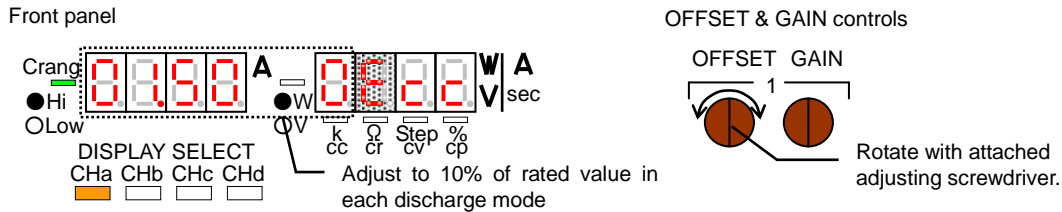

4. Set the external voltage to 9 V. Set the value displayed on the A and V. W display units to 90% of the rated value in each discharge mode with the GAIN control. Set it to "27000" (step value) in the CR mode.

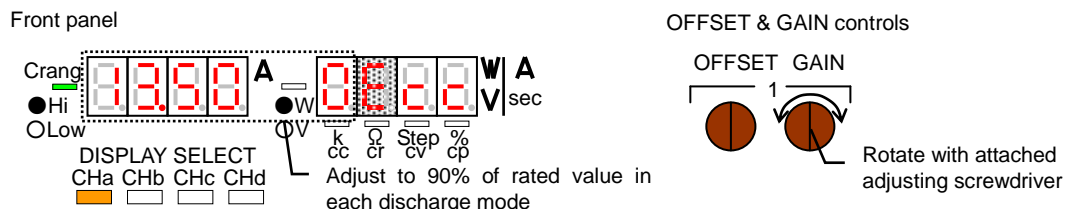

5. Repeat steps 5 and 6 several times.

NOTE: Be sure to carry out this adjustment if the discharge mode is changed (or the current range or voltage range is changed).

The OFFSET and GAIN controls may be set to other values than 10% and 90% of the rated value in each discharge mode. However, set them to values within the allowable setting range in each discharge mode.

The main input may be set to ON in this adjustment. In such a case, the value set by the external voltage control function displayed on the A and V. W display units in steps 5 and 6 is updated at the interval of approximately two seconds. As a result, it is very difficult to adjust the value with the OFFSET/GAIN control.

8-2-3 Operation in CC mode

The set value in the CC mode is the sum of the set value increased or decreased on the panel and the value set by the external voltage control function. Set 0 A on the panel when using the value set by the external voltage control function only.

1. Turn off the main input. Turn on the CONF and VAL keys. Set the current with the digit keys and rotary encoder.

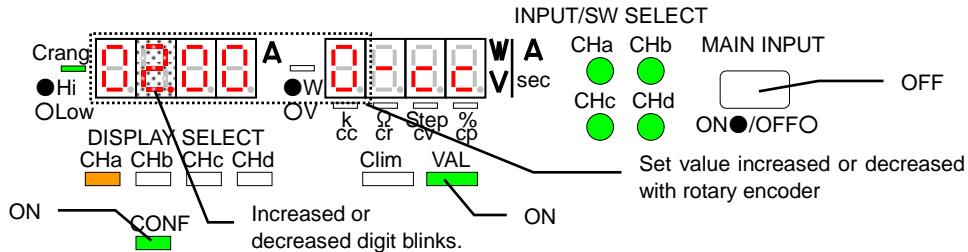

2. Apply any external voltage to J2. Turn on the CONF key and turn off the VAL key. The value set by the external voltage control function is displayed on the A and V/W display units.

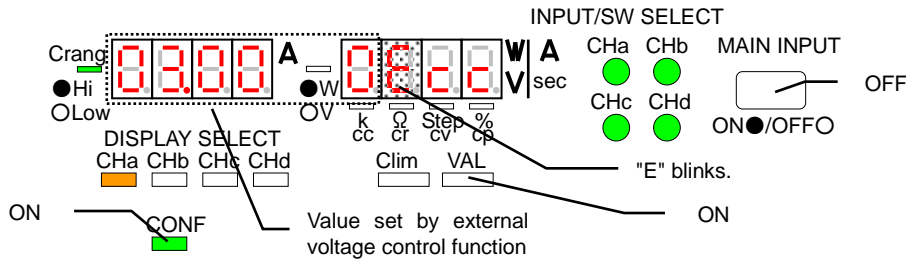

3. Turn on the main input. The current to which the currents set in steps 1 and 2 are added flows through the unit.

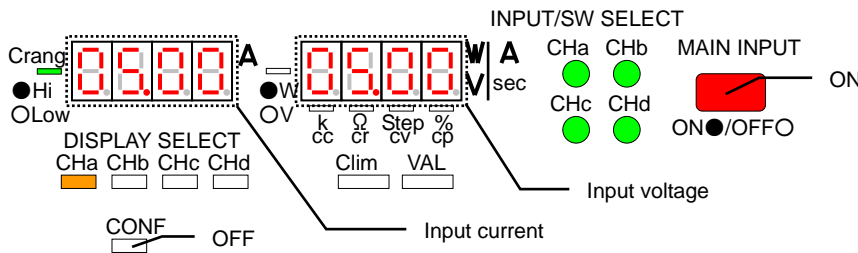

NOTE: It is impossible to change the sum of the set value increased or decreased on the panel and the value set by the external voltage control function.

The sum of the set value increased or decreased on the panel and the value set by the external voltage control function must be within the rated setting range.

While the main input is active, the value set by the external voltage control function is updated at the interval of approximately two seconds. If the external voltage is changed in this condition, the value set by the external voltage control function is also changed. However, the set value before changing the external voltage is displayed for a maximum of about four seconds.

8-2-4 Relationship between external voltage and set value in CC mode

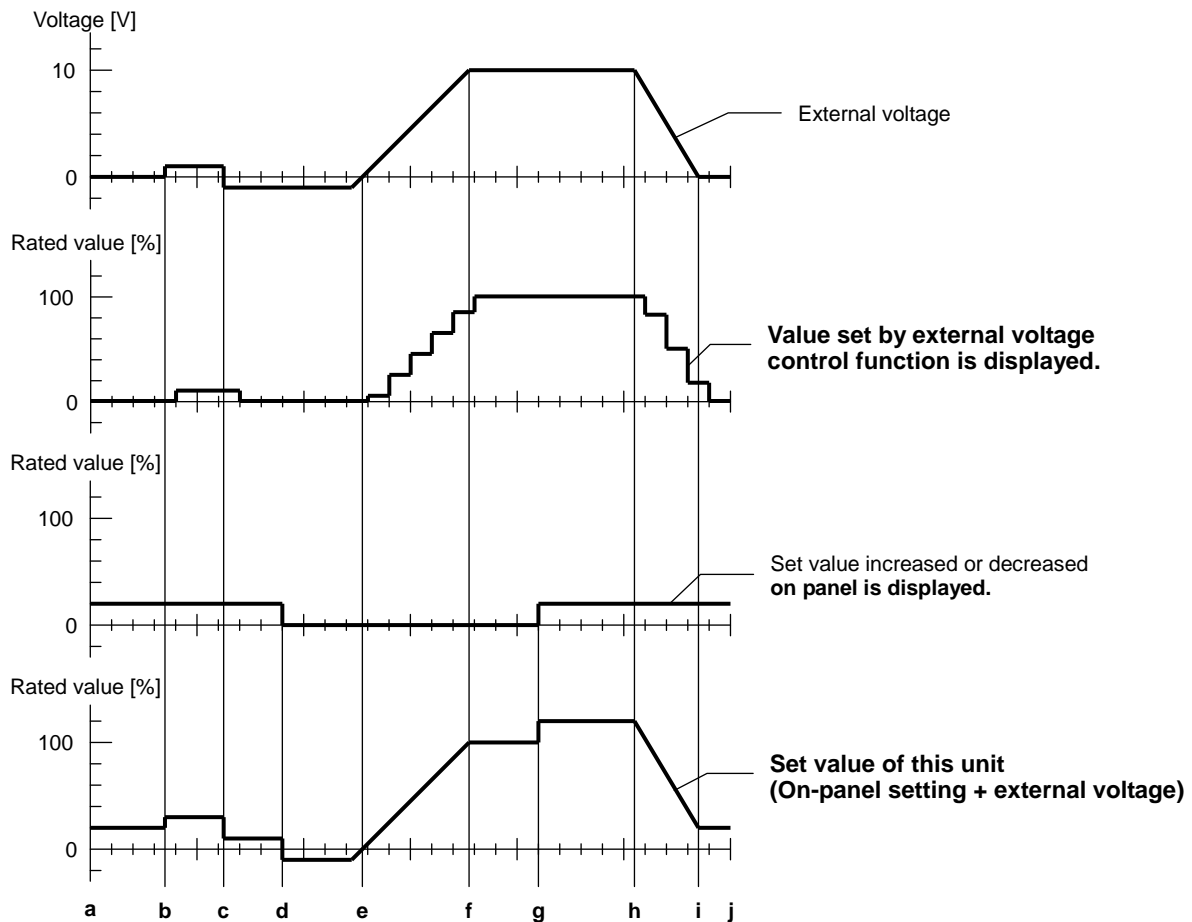

Description

- The horizontal axis of the graph above shows the interval of updating the displayed value set by the external voltage control function. The display updating interval is approximately 0.5 seconds when the main input is off or approximately 2 seconds while the main input is on.
- The displayed value set by the external voltage control function is changed as the external voltage is changed. If the external voltage change after the set value is updated, the value before the external voltage changes is displayed till it is updated next time.
- If negative external voltage is applied, the displayed set value is 0 A.
(Between the points c and e)
- When positive external voltage is applied, the set value of this unit becomes larger than the on-panel set value by the degree of the external voltage. (Between the points a and c and points g and i)
The unit may enter the OCA status if its set value exceeds the 100% rating. (Between the points g and h)
- When negative external voltage is applied, the set value of this unit becomes smaller than the on-panel set value by the degree of the external voltage. (Between the points c and e) No current flows through this unit if its set value lowers below the 0% rating.
(Between the points d and e)

8-2-5 Operation in CR/CV/CP mode

The value set by the external voltage control function serves as the set value in any other modes than the CC mode. It is impossible to increase or decrease the set value on the panel in any mode than the CC mode.

1. Apply any external voltage to J2. Turn on the CONF key and turn off the VAL key. The value set by the external voltage control function is displayed on the A and V./W display units.
2. Turn on the main input. The current set in step 1 flows through the unit.

NOTE: When the value is set using external voltage, it is impossible to set any value exceeding the setting range of each discharge mode. While the main input is active, the value set by the external voltage control function and its display value are updated at the interval of approximately two seconds. If the external voltage is changed in this condition, the value set by the external voltage control function and its display value before changing the external voltage are displayed for a maximum of about four seconds.

8-2-6 Relationship between external voltage and set value in CR/CV/CP mode

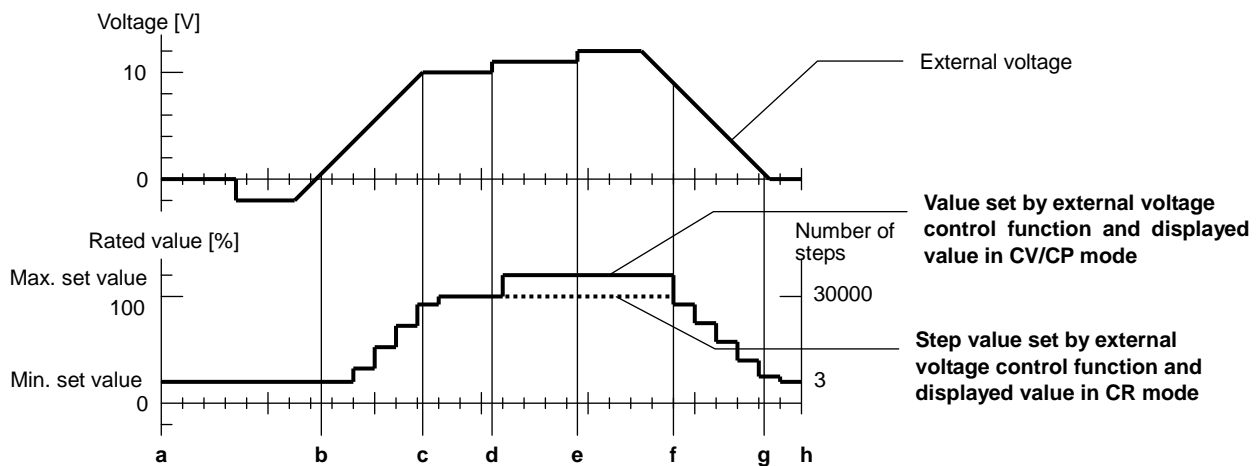

Description

- The horizontal axis of the graph above shows the interval of updating the displayed value and the value set by the external voltage control function. The display updating interval is approximately 0.5 seconds when the main input is off or approximately 2 seconds while the main input is on.
- The displayed value and the set by the external voltage control function are changed after the set value and display are changed. If the external voltage changes after the set value and displayed value are updated, the values before the external voltage changes are displayed till it is updated next time.
- If negative external voltage is applied, the displayed set value is 0 A.
(Between the points c and e)
- If the external voltage is lower than the voltage equivalent to the minimum set value (including negative voltage), the value set by the external voltage control function and the displayed value are the minimum value in each discharge mode.
(Between the points a and b and the points g and h)
- If the external voltage is higher than the voltage equivalent to the maximum set value, the value set by the external voltage control function and the displayed value are the maximum value in each discharge mode. (Between the points d and f)

9. REMOTE CONTROL

Terminology

Master unit

A unit that controls the slave units.

Slave unit

The LW unit connected with the local bus master through the local bus when using the IF-50GP/USB.

Local bus

Bus lines that connect the LW units. Twisted pair cables are used when using the IF-50GP/USB.

Local bus master

The LW unit connected directly with a computer when using the IF-50GP/USB.

9-1 Connection of IF-50GP or IF-50USB

- It is possible to control the LW unit with the IF-50GP built in through the GP-IB. It is possible to control the LW unit with the IF-50USB built in through USB.
- It is necessary to set the PC address and system address of the local bus master when controlling the LW units through the GP-IB or USB. Set the system address to the slave unit.
- The LW series may only be connected.

9-1-1 Control through GP-IB

- It is possible to connect a maximum of 14 local bus masters directly with a computer using GP-IB cables. It is possible to connect a maximum of 31 slave units with the local bus master directly connected with the computer using a couple of twisted pair cables.

9-1-2 Control through USB

- It is possible to connect a maximum of 32 local bus masters (except the hub) directly with a computer using USB cables. It is possible to connect a maximum of 31 slave units with the local bus master directly connected with the computer using a couple of twisted pair cables.
- The LW series may only be connected.

9-1-3 Connection Figure of IF-50GP/USB

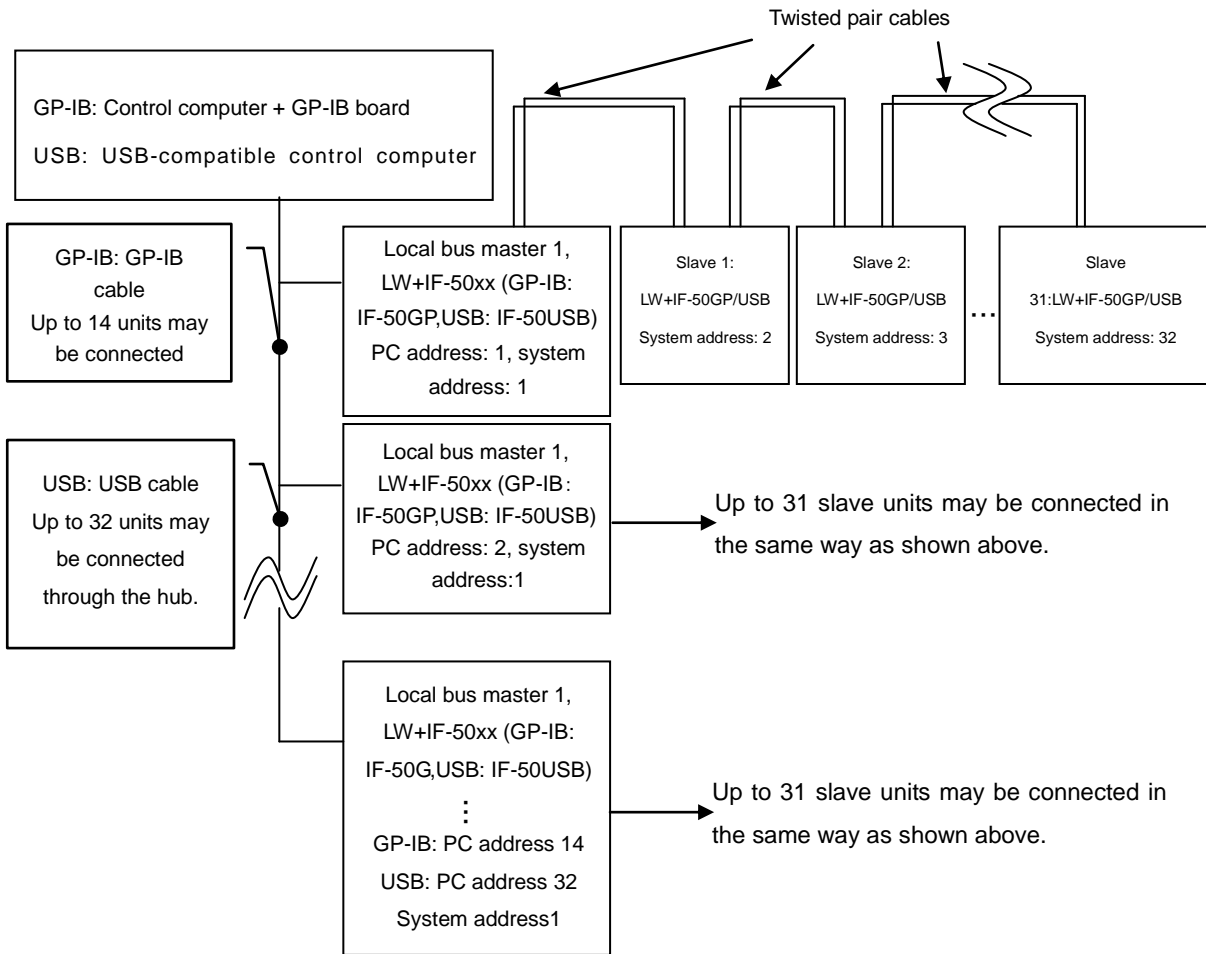

GP-IB/USB Control using IF-50GP/USB

9-1-4 Connection of IF-50GP/USB local bus

Observe the following instructions and connect the local bus with twisted pair cables.

- The total length of the bus must be 200 meters or less. Its resistance must be 50Ω.
- Turn on both switches S1 of the local bus masters and the IF-50GP/USB connected at the end of the bus only. S1: Termination resistor On/Off selector switch. Turned on when the lever is set at the upper position.
- The wires to be connected with the connector J1 of the IF-50GP/USB should meet the following ratings.
 - * Single conductor: 0.4 to 1.2 mm in diameter
 - * Stranded wires: 0.3 to 1.2 m²/AWG 16 to 22Conductor diameter: 0.18 or more

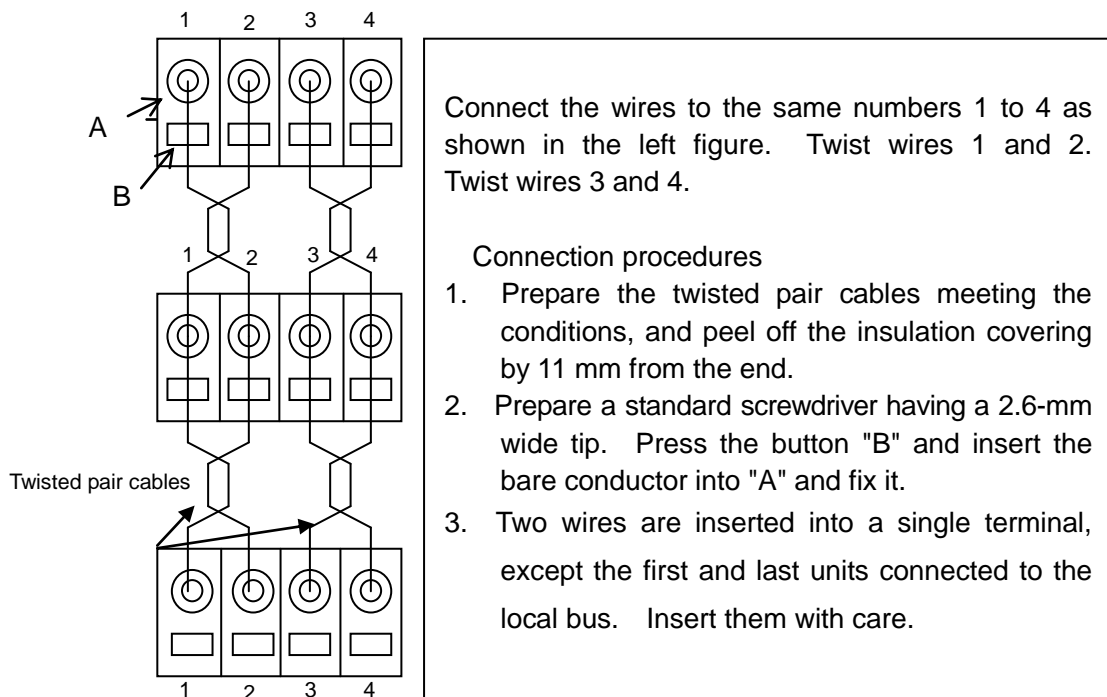

Local Bus Connection

9-2 Address Setting

9-2-1 Addresses

It is necessary to set the addresses of the units before using the remote control functions. The addresses are classified into the system addresses and PC addresses.

System addresses

The system addresses are used to identify the LW units. It is necessary to assign the system addresses to all units to be remote-controlled.

PC addresses

It is necessary to assign the PC addresses to the local bus masters connected with the computer through the GP-IB or USB. When the GP-IB is used, the PC addresses equal to the GP-IB addresses. When USB is used, the PC addresses serve as the unit-identifying parameters. When a PC address is assigned to the unit, the system address must be 1 (local bus master 1).

9-2-2 Address setting

1. Hold the C-lim key of the unit, and throw the power switch. "SyAd" is displayed on the A display unit.
2. Every press of the STATUS key alternates "SyAd" and "PcAd" displayed on the A display unit.
3. Set the system address displayed on the V/W display unit with the rotary encoder when "SyAd" is displayed on the A display unit. Set the PC address displayed on the V/W display unit with the rotary encoder when "PcAd" is displayed on the A display unit.
4. Press the MEMORY key after setting the system address and PC address. These addresses are saved in the built-in EEPROM. The normal display is restored when the addresses are saved in the built-in EEPROM.

9-2-3 Address setting range and set value

Optional board	Connection method	System address	PC address
IF-50GP	GP-IB control: Slave unit	2 to 32	—
	Local bus master	1	0 to 31
IF-50USB	USB control: Slave unit	2 to 32	—
	Local bus master	1	0 to 31

- The numbers of the addresses differ from the number of connectable units.
- The system address and PC address are 1 by default or when the memory is initialized.
- Do not assign the same PC address to several local bus masters when the IF-50GP/USB is used. Do not assign the same address to any slave units connected with the local bus master through the local bus. Otherwise, normal operation is disabled.
- The PC addresses assigned to the units connected with the computer through USB are similar to the IDs for unit identification. They are different from the USB addresses. The computer automatically assigns the USB addresses to the USB devices and the user need not assign them.
- In GP-IB connection, the unit having PC address 31 operates in the listen-only mode.

9-3 Precautions for Using GP-IB or USB

9-3-1 Using GP-IB

Recommended GP-IB board: The PCI-GPIB or PCMCIA-GP-IB made by National Instruments. Note that any other GP-IB board may not guarantee normal operation.

Delimiter: The following delimiters are only valid in commands to be sent to the unit.

LF only, CR, LF, LF + EOI, CR, LF + EOI, EOI only

CR and LF + EOI are only valid in messages sent by the unit. It is impossible to deactivate EOI using the IF-50GP.

9-3-2 Using USB

- The vendor ID is 098F (hexadecimal).
- The product ID of the IF-50USB is 1002 (hexadecimal).
- USB delimiter: The following delimiters are only valid in commands to be sent to the unit.
LF + null packet, CR, LF + null packet, null packet only
- If the USB driver is needed, you may download it from the homepage shown below.
Contact our agent if it is impossible to download it.

<http://www.texio.co.jp/>

You may also download API and sample programs.

9-4 Precautions for Sending Commands

9-4-1 Sending commands

- It is possible to write several commands on a single line by separating them with the separators ";" when sending them through the GP-IB or USB. The maximum of 80 characters may be written on a single line. (Multi-command function)
- If an error occurs when sending a command, that command is ignored and the next command is executed. When several query commands are sent, the last command is only executed.
- Send the "SV" command for selecting a unit to be controlled before other commands.
Or, send it alone.
- The time of executing a command is delayed by several dozens of milliseconds among the slave units.

9-4-2 Command format

Each command consists of an alphabetic command operand, which indicates the details of the command, and a parameter (alphabetic or numeric). Separate the command operand and parameter with one space or more. If the command operand or parameter has a space in it, the parameter is out of the allowable range, or an unused channel or function is specified, that command causes an error and is not executed.

Example:

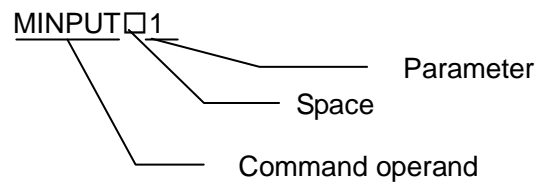

NOTE: All command operands, spaces and parameters must be written in half-size capital letters.

10. COMMANDS

10-1 Setting Commands

10-1-1 Setting units to be controlled

Command name : SV

Function : Sets a system address of an electronic load to be controlled.

Command format : SV□**sa** (, **sa**, ..., **sa**)

sa : 0, 1 to 32

This command sets a system address of an electronic load to be controlled. 0 shows broadcasting and allows all electronic loads connected with a specified local bus master to be controlled. This command is set to 0 (broadcasting) when power is turned on.

NOTE: It is possible to specify several units as units to be controlled by writing their system addresses.

This command is executed before other commands. However, a response to a query command is only made to the unit of the system address written last. (In broadcasting, the local master only makes a response to a query command.)

This command does not establish the remote mode.

Example: SV 1,2,31;MINPUT 1 ... Turns on the main inputs of the units of system addresses 1, 2 and 31.

SV 1,2;MINPUT 1;SV 31;MINPUT 0 ... Sends the MINPUT 1 and MINPUT 0 commands to the unit of system address 31.

10-1-2 PRESET key selection

Command name : PRESET

Function : Selects a PRESET key.

Command format : PRESET□**pre**

pre : Key to be selected

1: PRESET 1 key, 2 : PRESET 2 key, 3: PRESET 3 key, 4: PRESET 4 key

Example: PRESET 2 ... Selects the PRESET 2 key.

10-1-3 Discharge mode setting

Command name : LMODE

Function : Sets the discharge mode.

Command format : LMODE□**pre**, **ch**, **mode**, **ref**

pre : PRESET key

1: PRESET 1 key, 2 : PRESET 2 key, 3: PRESET 3 key, 4: PRESET 4 key

ch : Channel

1: Channel A, 2: Channel B, 3: Channel C, 4: Channel D

mode : Discharge mode specification

- 1: Selects the CC mode and H current range.
- 2: Selects the CC mode and L current range.
- 3: Selects the CR mode and H current range.
- 4: Selects the CR mode and L current range.
- 5: Selects the CV mode and H current range.
- 6: Selects the CV mode and L current range.
- 7: Selects the CP mode, H current range, and L voltage range.
- 8: Selects the CP mode, H current range, and H voltage range.
- 9: Selects the CP mode, L current range, and L voltage range.
- 10: Selects the CP mode, L current range, and H voltage range.
- 11: Selects the short circuit mode.

ref : Selects external voltage control.

0: No external voltage control, **1**: External voltage control

NOTE: This command is not executed unless the preset condition of a PRESET key specified with this command is the same as the preset condition currently selected if the main input is active. The changes made with this command are saved in the EEPROM.

Example: LMODE 1,2,4,0 ... Selects the CR discharge mode and L current range without external voltage control in the channel B of PRESET 1.

10-1-4 Main input ON/OFF

Command name : MINPUT

Function : Turns on or off the main input.

Command format : MINPUT **flg**

flg : Main input ON/OFF setting

0: OFF, **1**: ON

Example: MINPUT 1 ... Turns on the main input.

10-1-5 Input select ON/OFF

Command name : INPSEL

Function : Turns on or off the input select of each channel.

Command format : INPSEL **ch**, **flg**

ch : Channel

1: Channel A, **2**: Channel B, **3**: Channel C, **4**: Channel D

flg : Turns on or off input select.

0: OFF, **1**: ON

NOTE: The LW301-151S may not execute this command.

Example: INPSEL 1,1 ... Turns on input select of the channel A.

10-1-6 Setting discharge mode set value

Command name : VALUE

Function : Sets a set value in each discharge mode.

Command format : VALUE □ pre, ch, data

pre : PRESET key

1: PRESET 1 key, 2 : PRESET 2 key, 3: PRESET 3 key, 4: PRESET 4 key

ch : Channel

1: Channel A, 2: Channel B, 3: Channel C, 4: Channel D

data : Set data

Real number data (in the units shown below). A maximum of ten characters (including the decimal point)

Current: A, voltage: V, resistance: Ω , power: W

NOTE: 1) This command is not executed if the set data is over or below the allowable range of the selected channel.

2) When the selected channel is in the CR mode, this command sets resistance (Ω).

3) This command is not executed if the selected channel is in the short circuit mode.

4) This command does not save the set data in the EEPROM.

Example: VALUE 1,1,1.0 ... Sets a value of 1.0 in the channel A of the PRESET 1 key.

10-1-7 Setting STEP value of CR mode

Command name : SVALUE

Function : Sets a STEP value of the CR mode.

Command format : SVALUE □ pre, ch, data

pre : PRESET key

1: PRESET 1 key, 2 : PRESET 2 key, 3: PRESET 3 key, 4: PRESET 4 key

ch : Channel

1: Channel A, 2: Channel B, 3: Channel C, 4: Channel D

data : STEP data

Integer data (3 to 30000). A maximum of five characters.

NOTE: 1) This command is not executed if the set data is over or below the allowable STEP value range.

2) This command is not executed if the selected channel is in the CR mode.

3) This command does not save the set data in the EEPROM.

Example: SVALUE 1,1,3 ... Sets a STEP value of 3 in the channel A of the PRESET 1 key.

10-1-8 Setting current limit value

Command name : CLIM

Function : Sets the current limit value.

Command format : CLIM□**pre**, **ch**, **data**

pre : PRESET key

1: PRESET 1 key, **2** : PRESET 2 key, **3**: PRESET 3 key, **4**: PRESET 4 key

ch : Channel

1: Channel A, **2**: Channel B, **3**: Channel C, **4**: Channel D

data : Current limit value

Real number data in units of A. A maximum of ten characters (including the decimal point).

NOTE: 1) This command is not executed if the set data is over or below the allowable range.

2) This command is not executed if the selected channel is in the CC or short circuit mode.

3) This command does not save the set data in the EEPROM.

Example: CLIM 1,1,1.0 ... Sets the current limit value of 1.0 in the channel A of the PRESET 1 key.

10-1-9 Saving preset data in EEPROM

Command name : SETPRE

Function : Saves the preset data in the EEPROM.

Command format : SETPRE□**pre1**, **pre2**

pre1 : PRESET key whose data are to be saved

1: PRESET 1 key, **2** : PRESET 2 key, **3**: PRESET 3 key, **4**: PRESET 4 key

pre 2 : PRESET key to which data are to be assigned

1: PRESET 1 key, **2** : PRESET 2 key, **3**: PRESET 3 key, **4**: PRESET 4 key

Example: SETPRE 1, 2 ... Saves the preset data of the PRESET 1 key in the EEPROM as the preset data of the PRESET 2 key.

SETPRE 1,1 ... Saves the preset data of the PRESET 1 key in the EEPROM.

10-1-10 Turning on or off switching select function

Command name : SWSEL

Function : Turns on or off the switching select function .

Command format : SWSEL□**ch**, **flg**

ch : Channel

1: Channel A, **2**: Channel B, **3**: Channel C, **4**: Channel D

flg : Turns on or off the switching select function .

0: OFF, **1**: ON

NOTE: This command is not executed if the selected channel is incapable of switching.

Example: SWSEL 1,1 ... Turns on the switching select function of the channel A.

10-1-11 Setting switching frequency

Command name : SWFREQ

Function : Sets the switching frequency.

Command format : SWFREQ□

: Switching frequency

Integer data (1 to 500) in units of Hz. A maximum of three characters.

NOTE: 1) This command is not executed if the switching method is "Ta time and Tb time".

2) This command does not save the set data in the EEPROM.

Example: SWFREQ 1 ... Sets the switching frequency to 1 Hz.

10-1-12 Setting switching duty

Command name : SWDUTY

Function : Sets the switching duty.

Command format : SWDUTY□

: Set data

Integer data (5 to 95) in units of %. A maximum of two characters.

NOTE: 1) This command is not executed if the switching method is "Ta time and Tb time".

2) This command does not save the set data in the EEPROM.

Example: SWDUTY 90 ... Sets the switching duty to 90%.

10-1-13 Setting switching time

Command name : SWTIME

Function : Sets the Ta time and Tb time.

Command format : SWTIME□,

: Ta time

Real number data (0.1 to 950.0) in units of ms. A maximum of five characters (including the decimal point).

: Tb time

Real number data (0.1 to 950.0) in units of ms. A maximum of five characters (including the decimal point).

NOTE: 1) This command is not executed if the frequency and duty calculated from the set Ta time and Tb time are over or below the allowable range.

2) This command is not executed if the switching method is "frequency and duty".

3) This command does not save the set data in the EEPROM.

Example: SWTIME 10.0,20.0 ... Sets the switching time ta to 10 ms and tb to 20 ms.

10-1-14 Changing switching method

Command name : SWSET

Function : Changes the switching setting method

Command format : SWSET□**flg**

flg : Switching method

0: frequency and duty, **1**: Ta time and Tb time

NOTE: 1) The switching parameter is set again in accordance with the specified setting method after completion of setting.

2) Changed setting is saved in the EEPROM.

Example: SWSET 0 ... Sets the "frequency and duty" switching method.

10-1-15 Turning on/off delay operation

Command name : DELAY

Function : Turns on or off the delay operation.

Command format : DELAY□**flg**

flg : Delay operation

0: OFF, **1**: ON

Example: DELAY 1 ... Turns on the delay operation.

10-1-16 Setting delay time

Command name : DLYTIM

Function : Sets the delay time.

Command format : DLYTIM□**ch**, **time**

ch : Channel

1: Channel A, **2**: Channel B, **3**: Channel C, **4**: Channel D

time : Set time

Real number data (0.00 to 10.00) in units of seconds. A maximum of five characters (including the decimal point).

NOTE: This command does not save the set data in the EEPROM.

Example: DLYTIM 1,5.0 ... Sets the delay time of the channel A to 5 seconds.

10-1-17 Saving set values in EEPROM

Command name : MEMWRT

Function : Saves the set values in the EEPROM.

Command format : MEMWRT□**obj**

obj : Set value to be saved

1: Switching frequency, **2**: switching duty, **3**: switching time (Ta time and Tb time), **4**: Delay time, **5**: Tracking

Example: MEMWRT 1 ... Saves the switching frequency in the EEPROM.

10-1-18 Saving discharge mode set value in EEPROM

Command name : VALWRT

Function : Saves the discharge mode set value in the EEPROM.

Command format : VALWRT □ ,

: PRESET key

1: PRESET 1 key, 2 : PRESET 2 key, 3: PRESET 3 key, 4: PRESET 4 key

: Channel

1: Channel A, 2: Channel B, 3: Channel C, 4: Channel D

Example: VALWRT 1,1 ... Saves the set value of the channel A of the PRESET 1 key in the EEPROM.

10-1-19 Saving current limit value in EEPROM

Command name : CLMWRT

Function : Saves the current limit value in the EEPROM.

Command format : CLMWRT □ ,

: PRESET key

1: PRESET 1 key, 2 : PRESET 2 key, 3: PRESET 3 key, 4: PRESET 4 key

: Channel

1: Channel A, 2: Channel B, 3: Channel C, 4: Channel D

Example: CLMWRT 1,1 ... Saves the current limit value of the channel A of the PRESET 1 key in the EEPROM.

10-1-20 Setting time-out time

Command name : TOUT

Function : Sets the time-out time.

Command format : TOUT □

: Time-out time

Integer data (0 to 10) in units of minutes. A maximum of two characters. 0: No time-out.

NOTE: This command saves the time-out time in the EEPROM.

Example: TOUT 1 ... Sets the time-out time to 1 minute.

10-1-21 Resetting alarms

Command name : ALMRST

Function : Executes alarm resetting.

Command format : ALMRST

NOTE: It is impossible to reset an alarm unless the alarm cause is eliminated.

Example: ALMRST ... Executes alarm resetting.

10-1-22 Selecting input value display channel

Command name : DISPSEL

Function : Selects a channel whose input value is to be displayed on the V/W and A display units.

Command format : DISPSEL□

: Channel

1: Channel A, **2**: Channel B, **3**: Channel C, **4**: Channel D

NOTE: 1) In the remote mode, the input value is always displayed on the V/W and A display units. 2) The LW301-151S may not execute this command.

Example: DISPSEL 1 ... Selects the input value of the channel A.

10-1-23 Selecting input value to be displayed

Command name : MONSEL

Function : Specifies the input value to be displayed on the V/W display unit, voltage or current.

Command format : MONSEL□

: Monitor specification

0: Voltage, **1**: current

Example: MONSEL 1 ... Displays the power.

10-1-24 Local setting (Canceling key locking)

Command name : LOCAL

Function : Turns off the ESC/KEY LOCK key and enables operation of the unit on the front panel.

Command format : LOCAL

Example: LOCAL ... Executes local setting (canceling key locking).

10-1-25 Setting lockout status

Command name : LOCKOUT

Function : Disables remote mode cancellation (moving to the local mode) on the panel of the unit.

Command format : LOCKOUT□

: Lockout status

0: Remote mode cancellation enabled on the panel, **1**: remote mode cancellation disabled on the panel

NOTE: 1) In the condition where remote mode cancellation is disabled, the LOCAL command may only cancel the remote mode.

2) Remote mode cancellation on the panel is disabled when the setting command brings the unit into the remote mode even after the LOCAL command cancels the remote mode. Such a condition lasts until the "LLO 0" command is sent.

3) When power is turned on, remote mode cancellation is enabled on the panel.

Example: LOCKOUT 1 ... Remote mode cancellation enabled on the panel.

10-1-26 Tracking setting

Command name : TRSET

Function : Sets tracking in each channel.

Command format : TRSET

seta : Sets tracking of channel A.

0: No tracking, **1**: + tracking, **2**: - tracking

setb : Sets tracking of channel B.

0: No tracking, **1**: + tracking, **2**: - tracking

setc : Sets tracking of channel C.

0: No tracking, **1**: + tracking, **2**: - tracking

setd : Sets tracking of channel D.

0: No tracking, **1**: + tracking, **2**: - tracking

NOTE: 1) The LW301-151S may not execute this command.

2) This command is not executed if the unit is in the tracking ON status.

Example: TRSET 0,1,1,2 ... No tracking is set in the channel A, + tracking is set in the channels B and C, and - tracking is set in the channel D.

10-1-27 Setting tracking mode

Command name : TRMODE

Function : Specifies the set value increasing/decreasing method in tracking operation, absolute value tracking or % tracking.

Command format : TRMODE

mode : Tracking mode

0: %, **1**: absolute value

NOTE: 1) The LW301-151S may not execute this command.

2) This command is not executed if the unit is in the tracking ON status.

Example: TRMODE 1 ... Increases or decreases the set value by absolute values.

10-1-28 Turning On/Off tracking operation

Command name : TRACK

Function : Specifies whether to turn on or off the tracking operation.

Command format : TRACK

trc : Tracking operation

0: OFF, **1**: ON

NOTE: 1) The LW301-151S may not execute this command.

2) If this command is sent in the condition where the tracking function is activated on the panel, the unit deactivates the tracking function once and activates it then.

3) In the % tracking mode, the set value when receiving this command serves as 100%.

4) The tracking function is deactivated when the status of this unit changes from Remote into Local.

5) This command is not executed unless all channels where tracking is set meet the tracking conditions.

Example: TRACK 1 ... Activates the tracking operation.

10-1-29 Increasing/decreasing set value in tracking operation

Command name : TRVAL

Function : Increases or decreases the set value in tracking operation.

Command format : TRVAL□**data**

data : Amount of increase/decrease

Input an increase/decrease amount in a real number in the absolute value tracking mode. The units of the increase/decrease amount are A in the CC mode, V in the CV mode, steps in the CR mode, and W in the CP mode.

A maximum of ten characters (including the decimal point).

Input a relative increase/decrease amount in units of % in the % tracking mode.

A maximum of five characters (including the decimal point).

NOTE: 1) The LW301-151S may not execute this command.

2) If the set data is over or below the allowable range in the discharge mode of the channel, it is reset to the maximum or minimum value of that mode.

3) This command does not write the set data in the EEPROM.

4) It is impossible to input any negative value in the % tracking mode.

Example: TRVAL 1.0 ... Sets the increase/decrease amount of +1.0.

TRVAL -1.0 ... Sets the increase/decrease amount of -1.0.

10-2 Query Commands

10-2-1 Sending system addresses of controlled units

Command name : SV?

Function : Checks the system addresses of controlled units.

◇Query

Command format : SV?

◇Response

Command format : SV□**qra**, **ssa**

qra : System address in response to the query command

ssa : The system addresses of the controlled units are displayed in sequence.

NOTE: This command does not establish the remote mode.

Example: SV? ... Inquires about the system addresses of the controlled units.

SV 2,1,2,31 ... The system address in response to the query command is 2.

The system addresses of the controlled units are 1, 2 and 31.

10-2-2 Sending addresses of all slave units

Command name : SLV?

Function : Checks the system addresses of all connected slave units.

◇Query

Command format : SLV?

◇Response

Command format : SLV□**sla**

sla : The system addresses of all connected slave units are displayed in sequence.

NOTE: 1)"SLV" is only displayed if no units are connected.

2) "1" is the system address of the local bus master. Thus, "1" will not be returned in response to the SLV? command.

3) This command does not establish the remote mode.

Example: SLV? ... Inquires about the system addresses of all connected slave units.
SLV 2, 31 ... The system addresses of the connected slave units are 2 and 31.

10-2-3 Sending option board ID and model ID of unit

Command name : * IDN?

Function : Inquires about the ID of the option board built in the local bus master and the model ID of this unit.

◇Query

Command format : * IDN?

◇Response

Command format : * IDN□, , ,

: Company name, which is TEXIO

: Model name of the option board

: Always 0

: ROM version of the option board

NOTE: This command does not establish the remote mode.

Example: * IDN? ... Inquires about the ID of the option board built in the local bus master and the model ID of this unit.

* IDN TEXIO, IF-50GP, 0, 1.00 ... The mounted option board is the IF-50GP.

The ROM version of the IF-50GP is 1.00.

The units of the system addresses specified in the SV command parameter only return responses to the control computer in response to the query commands described below.

10-2-4 Query about input value

Command name : MONDATA?

Function : Inquires about an input value.

◇Query

Command format : MONDATA? □

: Channel

1: Channel A, 2: Channel B, 3: Channel C, 4: Channel D

◇Response

Command format : MONDATA□, , ,

: System address 1 to 32

: Input current

Real number data in units of A. 0 to 99.9999. A maximum of seven characters (including the decimal point).

: Input voltage

Real number data in units of V. 0 to 999.99. A maximum of six characters (including the decimal point).

: Input wattage

Real number data in units of W. 0 to 999.999. A maximum of seven characters (including the decimal point).

Example: MONDATA? 1 ... Inquires about the input value to the channel A.

MONDATA 1, 2.0, 15.2, 30.4... The input values to the channel A of system address 1 are current of 2.0 A, voltage of 15.2 V, and wattage of 30.4 W.

10-2-5 Query about selected PRESET key

Command name : PRESET?

Function : Inquires about a selected PRESET key.

◇Query

Command format : PRESET?

◇Response

Command format : PRESET ,

: System address **1 to 32**

: Selected PRESET key

1: PRESET 1 key, **2:** PRESET 2 key, **3:** PRESET 3 key, **4:** PRESET 4 key

Example: PRESET? ... Inquires about a selected PRESET key.

PRESET 1,1 ... The PRESET 1 key is selected on the unit of system address 1.

10-2-6 Query about discharge mode

Command name : LMODE?

Function : Inquires about the discharge mode.

◇Query

Command format : LMODE? ,

: PRESET key

1: PRESET 1 key, **2:** PRESET 2 key, **3:** PRESET 3 key, **4:** PRESET 4 key

: Channel

1: Channel A, **2:** Channel B, **3:** Channel C, **4:** Channel D

◇Response

Command format : LMODE ,

: System address **1 to 32**

: Discharge mode of the specified channel

1: CC mode, H current range.

2: CC mode, L current range.

3: CR mode, H current range.

4: CR mode, L current range.

5: CV mode, H current range.

6: CV mode, L current range.

7: CP mode, H current range, L voltage range.

8: CP mode, H current range, H voltage range.

9: CP mode, L current range, L voltage range.

10: CP mode, L current range, H voltage range.

11: Short circuit mode.

Example: LMODE? 1,1 ... Inquires about the discharge mode of the channel A of the PRESET 1 key.

LMODE 1,1 ... The discharge mode of the unit of system address 1 is the CC mode and the current range is H.

10-2-7 Query about main input On/Off status

Command name : MINPUT?

Function : Inquires about the On/Off status of the main input.

◇Query

Command format : MINPUT?

◇Response

Command format : MINPUT **sys** , **flg**

sys : System address **1 to 32**

flg : Main input status

0: Off, **1**: On

Example: MINPUT? ... Inquires about the On/Off status of the main input.

MINPUT 1,0 ... The main input of the unit of system address 1 is turned off.

10-2-8 Query about input select status

Command name : INPSEL?

Function : Inquires about the input select status.

◇Query

Command format : INPSEL? **ch**

ch : Channel

1: Channel A, **2**: Channel B, **3**: Channel C, **4**: Channel D

◇Response

Command format : INPSEL **sys** , **flg**

sys : System address **1 to 32**

flg : Input select status of the specified channel

0: Off, **1**: On

Example: INPSEL? 1 ... Inquires about the input select status of the channel A.

INPSEL 1,0 ... Input select of the unit of system address 1 is turned off.

10-2-9 Inquiry about set values

Command name : VALUE?

Function : Inquires about the set value of each discharge mode.

◇Query

Command format : VALUE? **pre** , **ch**

pre : PRESET key

1: PRESET 1 key, **2**: PRESET 2 key, **3**: PRESET 3 key, **4**: PRESET 4 key

ch : Channel

1: Channel A, **2**: Channel B, **3**: Channel C, **4**: Channel D

◇Response

Command format : VALUE **sys** , **data**

sys : System address **1 to 32**

data : Discharge set value

Real number data. The unit is A (current), V (voltage), ? (resistance) or W (power).
A maximum of eight characters (including the decimal point).

NOTE: When the specified channel is in the short circuit mode, the parameter of the response is "0".
Example: VALUE? 1,1 ... Inquires about the discharge mode set value of the channel A of the PRESET 1 key.
VALUE 1,1.0 ...The discharge mode set value of the unit of system address 1 is 1.0 A.

10-2-10 Query about STEP value in CR mode

Command name : SVALUE?

Function : Inquires about the STEP value in the CR mode.

◇Query

Command format : SVALUE? □ ,

: PRESET key

1: PRESET 1 key, 2 : PRESET 2 key, 3: PRESET 3 key, 4: PRESET 4 key

: Channel

1: Channel A, 2: Channel B, 3: Channel C, 4: Channel D

◇Response

Command format : SVALUE□ ,

: System address **1 to 32**

: STEP value in CR mode

Integer data between 3 and 30000. A maximum of five characters.

NOTE: This command is not executed unless the specified channel is in the CR mode.

Example: SVALUE? 1,1 ... Inquires about the STEP value of the channel A of PRESET 1.

SVALUE 1,30000 ... The STEP value of the unit of system address 1 is 30000.

10-2-11 Query about set current limit

Command name : CLIM?

Function : Inquires about the set current limit.

◇Query

Command format : CLIM? □ ,

: PRESET key

1: PRESET 1 key, 2 : PRESET 2 key, 3: PRESET 3 key, 4: PRESET 4 key

: Channel

1: Channel A, 2: Channel B, 3: Channel C, 4: Channel D

◇Response

Command format : CLIM□ ,

: System address **1 to 32**

: Set current limit

Real data in units of A. A maximum of six characters (including the decimal point).

NOTE: This command is not executed if the specified channel is in the short circuit mode or CC mode.

Example: CLIM? 1,1 ... Inquires about the set current limit of the channel A of PRESET 1.

CLIM 1,15.0 ... The set current limit of the unit of system address 1 is 15.0 A.

10-2-12 Query about switching select status

Command name : SWSEL?

Function : Inquires about the switching select status.

◇Query

Command format : SWSEL? □

: Channel

1: Channel A, **2:** Channel B, **3:** Channel C, **4:** Channel D

◇Response

Command format : SWSEL□ ,

: System address **1 to 32**

: Switching select status of the specified channel

0: Off, **1:** On

Example: SWSEL? 1 ... Inquires about the switching select status of the channel A.

SWSEL 1,0 ... Switching select of the unit of system address 1 is turned off.

10-2-13 Query about switching frequency

Command name : SWFREQ?

Function : Inquires about the switching frequency.

◇Query

Command format : SWFREQ?

◇Response

Command format : SWFREQ□ ,

: System address **1 to 32**

: Set switching frequency

Integer data. A maximum of three characters.

Example: SWFREQ? ... Inquires about the switching frequency.

SWFREQ 1,1 ... The switching frequency of the unit of system address 1 is 1 Hz.

10-2-14 Query about switching duty

Command name : SWDUTY?

Function : Inquires about the switching duty.

◇Query

Command format : SWDUTY?

◇Response

Command format : SWDUTY□ ,

: System address **1 to 32**

: Set switching duty

Integer data. A maximum of two characters.

Example: SWDUTY? ... Inquires about the switching duty.

SWDUTY 1,10 ... The switching duty of the unit of system address 1 is 10%.

10-2-15 Query about set switching time

Command name : SWTIME?

Function : Inquires about the set Ta time and Tb time.

◇Query

Command format : SWTIME?

◇Response

Command format : SWTIME□**sys**, **ta**, **tb**

sys : System address **1 to 32**

ta : Set Ta time

Real number data in units of ms. A maximum of five characters (including the decimal point).

tb : Set Tb time

Real number data in units of ms. A maximum of five characters (including the decimal point).

Example: SWTIME? ... Inquires about the set Ta time and Tb time.

SWTIME 1,10.0,20.0 ... The set Ta time and Tb time of the unit of system address 1 are 10.0 ms and 20.0 ms, respectively.

10-2-16 Query about switching method

Command name : SWSET?

Function : Inquires about the switching method.

◇Query

Command format : SWSET?

◇Response

Command format : SWSET□**sys**, **flg**

sys : System address **1 to 32**

flg : Switching setting method

0: Frequency and duty, **1**: Ta time and Tb time

Example: SWSET? ...Inquires about the switching method.

SWSET 1,0 ... The switching method of the unit of system address 1 is "frequency and duty".

10-2-17 Query about delay function On/Off status

Command name : DELAY?

Function : Inquires about the delay function On/Off status.

◇Query

Command format : DELAY?

◇Response

Command format : DELAY□**sys**, **flg**

sys : System address **1 to 32**

flg : Delay function status

0: Off, **1**: On

Example: DELAY? ... Inquires about the delay function On/Off status.

DELAY 1,0 ... The delay function of the unit of system address 1 is turned off.

10-2-18 Query about set delay time

Command name : DLYTIM?

Function : Inquires about the set delay time.

◇Query

Command format : DLYTIM? □ **ch**

ch : Channel

1: Channel A, 2: Channel B, 3: Channel C, 4: Channel D

◇Response

Command format : DLYTIM□ **sys**, **data**

sys : System address **1 to 32**

data : Set delay time

Real number data in units of seconds. A maximum of five characters (including the decimal point).

Example: DLYTIM? 1 ... Inquires about the set delay time of the unit of system address 1.

DLYTIM 1,5.0 ... The set delay time of the unit of system address 1 is 5.0 seconds.

10-2-19 Query about unit ID number

Command name : ID?

Function : Inquires about the unit ID number.

◇Query

Command format : ID?

◇Response

Command format : ID□ **sys**, **id**

sys : System address **1 to 32**

id : Model ID number

Integer data. A maximum of three characters.

Example: ID? ... Inquires about the unit ID number.

ID 1,1 ... The ID number of the unit of system address 1 is 1. (LW75-151Q)

10-2-20 Query about set time-out time

Command name : TOUT?

Function : Inquires about the set time-out time.

◇Query

Command format : TOUT?

◇Response

Command name : TOUT□ **sys**, **data**

sys : System address **1 to 32**

data : Set time-out time

Integer data. A maximum of two characters.

Example: TOUT? ... Inquires about the unit ID number.

TOUT 1 ... The set time-out time of the unit of system address 1 is one minute.

10-2-21 Query about alarm status

Command name : ALARM?

Function : Inquires about the alarm status.

◇Query

Command format : ALARM?

◇Response

Command format : ALARM□[sys], [eta], [oha], [ova], [oca], 0000

[sys] : System address **1 to 32**

[eta] : EAR status

0: Normal, **1**: alarm

[oha] : OHA status

0: Normal, **1**: alarm

[ova] : OVA status in the format of "XXXX". Channels A to D from the beginning of the parameter.

0: Normal, **1**: alarm

[oca] : OCA status in the format of "XXXX". Channels A to D from the beginning of the parameter.

0: Normal, **1**: alarm

NOTE: The alarm status of nonextant channels is always 0.

Example: ALARM? ... Inquires about the alarm status.

ALARM 1,0,0,0100,0000,0000... The channel B of the unit of system address 1 is in the OVA status.

10-2-22 Query about limit operation status

Command name : LIMIT?

Function : Inquires about the limit operation status.

◇Query

Command format : LIMIT?

◇Response

Command format : LIMIT□[sys], [cur], [pow]

[sys] : System address **1 to 32**

[cur] : CL operation status in the format of "XXXX". Channels A to D from the beginning of the parameter.

0: Normal, **1**: limit operating status

[pow] : OPL operation status in the format of "XXXX". Channels A to D from the beginning of the parameter.

0: Normal, **1**: limit operating status

Example: LIMIT? ... Inquires about the limit operation status.

LIMIT 1,0100,0000 ... The channel B of the unit of system address 1 is in the current limit status.

10-2-23 Query about input value display channel

Command name : DISPSEL?

Function : Inquires about the channel whose input is displayed.

◇Query

Command format : DISPSEL?

◇Response

Command format : DISPSEL ,

: System address **1 to 32**

: Channel

1: Channel A, **2**: Channel B, **3**: Channel C, **4**: Channel D

Example: DISPSEL? ... Inquires about the channel whose input is displayed.

DISPSEL 1,1 ... The input value of the channel A of the unit of system address 1 is displayed.

10-2-24 Query about displayed input value

Command name : MONSEL?

Function : Inquires about the displayed input value.

◇Query

Command format : MONSEL?

◇Response

Command format : MONSEL ,

: System address **1 to 32**

: Displayed input value

0: Voltage, **1**: power

Example: MONSEL? ... Inquires the displayed input value.

MONSEL 1,1 ... Voltage of the unit of system address 1 is displayed.

10-2-25 Query about local lockout status

Command name : LOCKOUT?

Function : Inquires whether the unit is in the local lockout status.

◇Query

Command format : LOCKOUT?

◇Response

Command format : LOCKOUT ,

: System address **1 to 32**

: Preset local lockout status

0: No local lockout status, **1**: Local lockout status

Example: LOCKOUT? ... Inquires about the local lockout status.

LOCKOUT 1,1 ... The unit of system address 1 is in the local lockout status.

10-2-26 Query about tracking setting

Command name : TRSET?

Function : Inquires about tracking setting in each channel.

◇Query

Command format : TRSET?

◇Response

Command format : TRSET□**sys**, **seta**, **setb**, **setc**, **setd**

sys : System address **1 to 32**

seta : Tracking setting of channel A

0: No tracking is set, **1**: + tracking is set, **2**: - tracking is set.

setb : Tracking setting of channel B

0: No tracking is set, **1**: + tracking is set, **2**: - tracking is set.

setc : Tracking setting of channel C

0: No tracking is set, **1**: + tracking is set, **2**: - tracking is set.

setd : Tracking setting of channel D

0: No tracking is set, **1**: + tracking is set, **2**: - tracking is set.

NOTE: The response parameter of nonextant channels is 0.

Example: TRSET? ... Inquires about tracking setting in each channel.

TRSET 2,1,1,1,1 ... + tracking is set in all channels of the unit of system address

10-2-27 Query about tracking mode

Command name : TRMODE?

Function : Inquires about the tracking mode.

◇Query

Command format : TRMODE?

◇Response

Command format : TRMODE□**sys**, **mode**

sys : System address **1 to 32**

mode : Tracking mode

0: % tracking mode, **1**: absolute value tracking mode

Example: TRMODE? ... Inquires about the tracking mode.

TRMODE 2,1 ... The unit of system address 2 is in the absolute value tracking mode.

10-2-28 Query about tracking operation On/Off status

Command name : TRACK?

Function : Inquires whether tracking operation is turned on or off.

◇Query

Command format : TRACK?

◇Response

Command format : TRACK□**sys**, **trc**

sys : System address **1 to 32**

trc : Tracking operation status

0: On, **1**: Off

Example: TRACK? ... Inquires about the tracking operation.

TRACK 2,1 ... Tracking operation of the unit of system address 2 is turned on.

10-2-29 Query about % tracking mode set value

Command name : TRVAL?

Function : Inquires about the set value in the % tracking mode.

◇Query

Command format : TRVAL?

◇Response

Command format : TRVAL□,

: System address **1 to 32**

: % tracking set value

Real number data (0.0 to 200.0). A maximum of five characters (including the decimal point).

NOTE: A value "999.9" is returned in response to this command if the unit is in the absolute tracking mode and tracking operation is turned off.

Example: TRVAL? ... Inquires about the tracking operation status.

TRVAL 2,110.0 ... The % tracking mode set value of the unit of system address 2 is 110.0%.

10-3 Command List

10-3-1 Setting commands

Page	Item	Command
68	Setting units to be controlled	SV system address, ..., system address
68	PRESET key selection	PRESET preset number
68	Discharge mode setting	LMODE preset specification, channel, discharge mode, external control setting
69	Main input ON/OFF	MINPUT ON/OFF
69	Input select ON/OFF	INPSEL channel, ON/OFF setting
70	Setting discharge mode set value	VALUE preset, channel, discharge mode set value
70	Setting CR mode STEP value	SVALUE preset, channel, CR mode STEP value
71	Setting current limit	CLIM preset, channel, current limit value
71	Saving preset data in EEPROM	SETPRE PRESET key with data to be saved, PRESET key to which data are allocated
71	Switching select ON/OFF	SWSEL channel, switching ON/OFF
72	Switching frequency setting	SWFREQ switching frequency
72	Switching duty setting	SWDUTY switching duty
72	Switching time setting	SWTIME Ta time and Tb time
73	Changing switching method	SWSET switching method
73	Delay operation ON/OFF	DELAY delay operation ON/OFF
73	Delay time setting	DLYTIM channel, delay time
73	Saving set values in EEPROM	MEMWRT set value to be saved
74	Saving discharge mode set value in EEPROM	VALWRT set value to be saved, channel
74	Saving set current limit in EEPROM	CLMWRT set value to be saved, channel
74	Setting time-out time	TOUT time-out time
74	Alarm resetting	ALMRST
75	Selecting input value display channel	DISPSEL channel
75	Selecting input value to be Displayed	MONSEL voltage/power
75	Local setting	LOCAL
75	Lockout status setting	LOCKOUT lockout
76	Tracking setting	TRSET channel A, channel B, channel C, channel D
76	Tracking mode setting	TRMODE mode
76	Tracking operation ON/OFF	TRACK ON/OFF
77	Increasing/decreasing tracking set Value	TRVAL set value increasing/decreasing value

10-3-2 Query commands

Page	Item	Command	Response
77	Sending system address of controlled units	SV ?	SV query command response address, controlled units' addresses
77	Sending addresses of all slave units	SLV ?	SLV all units' system addresses
78	Sending option board ID & model ID of unit	*IDN ?	* IDN company name, option board name, 0, ROM version
78	Query about input value	MONDATA? channel	MONDATA system address, current, voltage, power
79	Query about selected PRESET key	PRESET ?	PRESET system address, selected PRESET
79	Query about discharge Mode	LMODE? preset, channel	LMODE system address, discharge mode
80	Query about main input ON/OFF status	MINPUT ?	MINPUT system address, main input status
80	Query about main input ON/OFF status	INPSEL? channel	INPSEL system address, input select status
80	Query about discharge mode set value	VALUE? preset, channel	VALUE system address, discharge mode set value
81	Query about CR mode STEP value	SVALUE? preset, channel	SVALUE system address, CR mode STEP value
81	Query about set current limit	CLIM? preset, channel	CLIM system address, set current limit
82	Query about switching select status	SWSEL? channel	SWSEL system address, ON/OFF status
82	Query about switching Frequency	SWFREQ ?	SWFREQ system address, switching frequency
82	Query about switching duty	SWDUTY ?	SWDUTY system address, switching duty
83	Query about set switching Time	SWTIME ?	SWTIME system address, Ta time, Tb time
83	Query about switching Method	SWSET ?	SWSET system address, switching method
83	Query about delay operation ON/OFF	DELAY ?	DELAY system address, ON/OFF status
84	Query about delay time	DLYTIM? channel	DLYTIM system address, delay time
84	Query about unit ID	ID ?	ID system address, unit ID
84	Query about time-out time	TOUT ?	TOUT system address, time-out time
85	Query about alarm status	ALARM ?	ALARM system address, eta, oha, ova, oca, 0000,
85	Query about limit operation Status	LIMIT ?	LIMIT system address, cur, pow
86	Query about input value display channel	DISPSEL ?	DISPSEL system address, channel
86	Query about input value to be displayed	MONSEL ?	MONSEL system address, voltage/power
86	Query about local lockout Status	LOCKOUT ?	LOCKOUT system address, lockout status
87	Query about tracking setting	TRSET ?	TRSET system address, channel A setting, channel B setting, channel C setting, channel D setting
87	Query about tracking mode	TRMODE ?	TRMODE system address, tracking mode
87	Query about tracking ON/OFF status	TRACK ?	TRACK system address, ON/OFF status
88	Query about % tracking mode set value	TRVAL ?	TRVAL system address, % set value

11. TROUBLE-LOOKING PHENOMENA

Check the matters shown below if the unit operation condition becomes abnormal.

Phenomenon	Possible cause	Countermeasure
Power is not turned on even if power switch is thrown. (LED on front panel does not go on.)	AC cable is not connected properly or broken.	Connect the AC cable properly. Replace it if broken.
	Input AC voltage is too high, or the protection fuse has blown due to defects in the unit.	Replace the fuse and input the proper voltage.
	Input AC voltage is too low.	Input the proper voltage.
No current flows even if main input is turned on.	Voltage input to the unit is too low.	Raise the input voltage. (Front: 1.5 V, rear: 1 V)
	Too low current or too small current limit is set.	Increase the set current.
	INPUT SELECT key is not selected.	Turn on the INPUT SELECT key of the intended channel.
Main input may not be turned off.	External input function is turned on using the external contact control function.	Open the pins 3 (or 1) and 8 of the external contact control connector.
Input current is unstable or contains high-level noises.	Commercial frequency noises are detected due to too low input AC voltage.	Input the proper voltage.
	There is a strong magnetic field or electric field source.	Move the unit apart from the equipment that may be the magnetic field or electric field source, twist the cables, etc.

Contact our agent if some phenomenon not described above occurs or the unit may not be recovered from the abnormality even if the possible cause is eliminated.

12. OUTSIDE DIMENSIONS

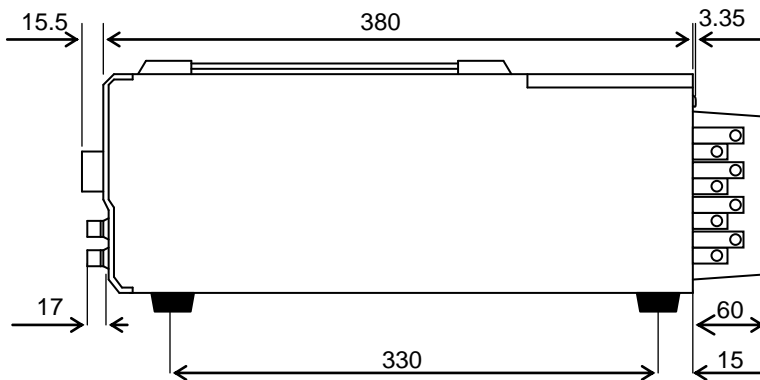
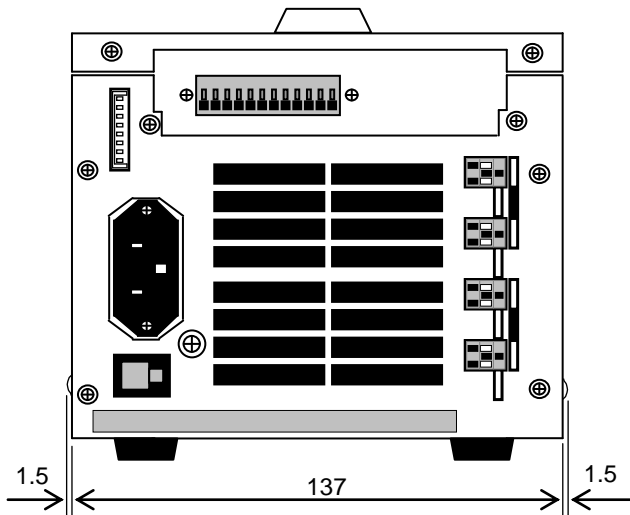
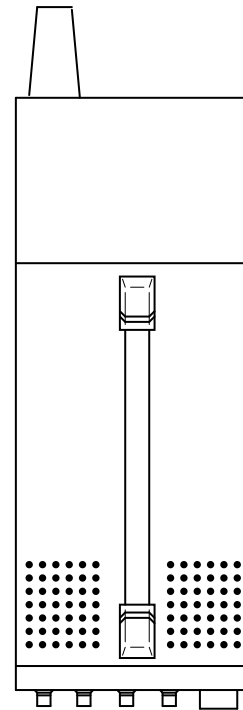
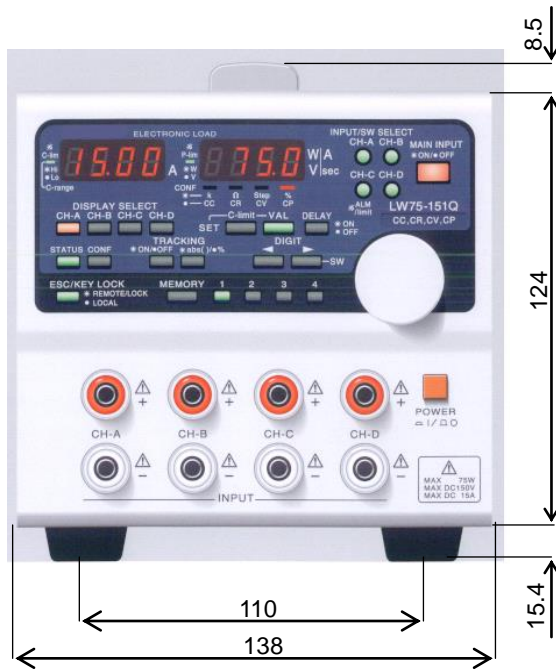



TEXIO TECHNOLOGY CORPORATION

7F Towa Fudosan Shin Yokohama Bldg.
2-18-13, Shin Yokohama, Kohoku-ku, Yokohama, Kanagawa, 222-0033 Japan
<http://www.texio.co.jp/>
